

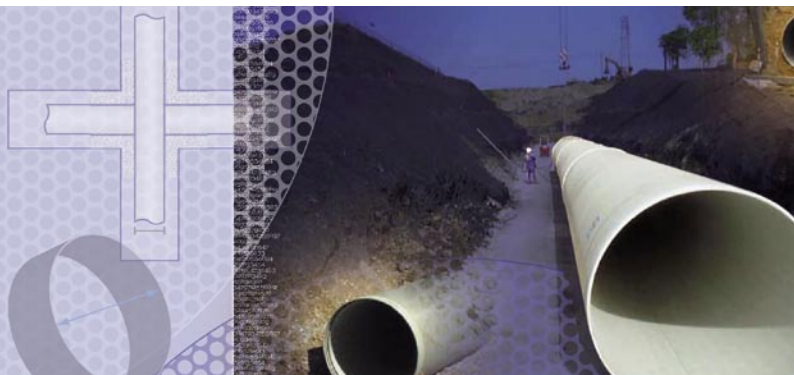

FLOWTITE

Installation Guide for Buried Pipes – AWWA
– abbreviated version –



AMIATIT PIPE SYSTEMS

1. INTRODUCTORY INFORMATION

This document is a part of the Flowtite documentation for the users of Flowtite products and is to be used for quick reference on site. This short version of the installation instructions should be used in connection with “Flowtite installation guide for buried pipe”. In case of further questions or for further information, please contact your local consultant, or the technical service department of the pipe manufacturer.

2. UNLOADING, HANDLING AND STORAGE

Make sure that no chains or steel cables are used to unload. Pipes can be lifted using only one holding point; however two holding points are preferred for safety reasons.

Do not lift the pipes using hooks at pipe ends or passing a rope, chain or cable through the section end to end (see **figure 1** →).

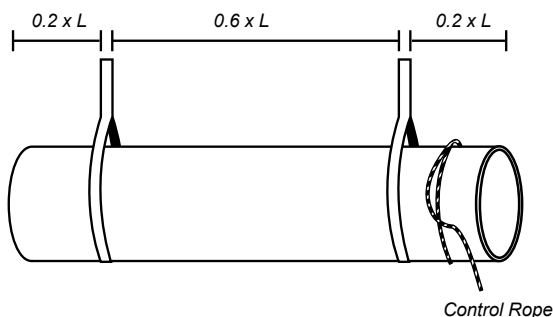

Figure 1 – Lifting a pipe using two hold points.

Pipe packages should be moved as shown in **Figure 1** using a pair of slings. The de-nesting of the pipes is best done using a forklift. The fork extensions should be fitted with edge protectors (see **figure 2** →).

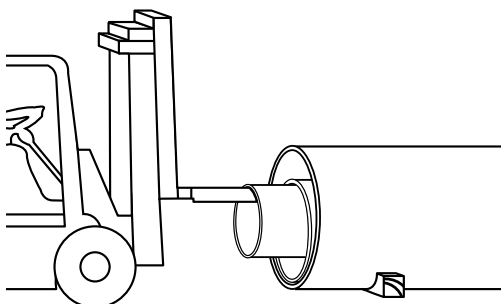
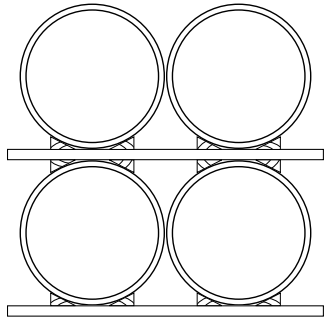

Figure 2 – De-nesting with padded boom on forklift truck

It is generally advantageous to store the pipes on flat wooden beams with a minimum width of 75 mm and to secure them with wedges (see figure 3 →).



The maximum stacking height is approx. 3 m.

Figure 3 – Storing pipe

3. PIPE LAYING

3.1 Pipe trenches

To ensure proper construction and employee safety, pipeline trenches have a typical value of “ $0.4 A * DN$ ” (see figure 4 →). For larger diameter pipes a smaller value for “A” may be adequate depending on the native soil, backfill material and compaction technique.

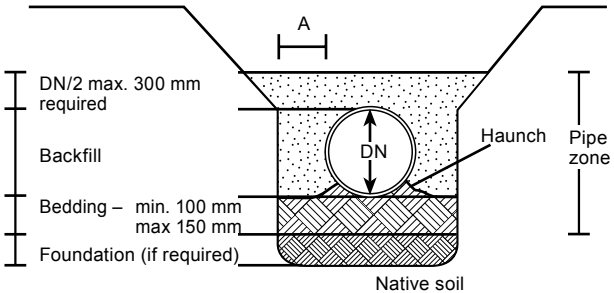

Figure 4 – Pipe backfill nomenclature

3.2 Bedding, and Backfill zone

The bedding should be placed over a firm, stable trench bottom to provide proper support (see figures 5 and 6 →).

The bedding should be 100-150 mm below the barrel and 75 mm below the coupling. For unstable soil, an additional foundation may be needed.

The bed should be over-excavated at each joint location to ensure that the pipe has a continuous support and does not rest on the coupling.

Suitable materials for use as bedding material or for the pipe zone to 300 mm above the pipe are preferably materials of categories SC1 and SC2. The degree of compaction should reflect the static requirements. Do not drop stones larger than 200 mm on the 300 mm layer from a height greater than 2 meters.

The backfill above the pipe zone may be made with excavated material with a maximum particle size of 300 mm. When the water table is above the trench bottom, the water level must be lowered to at least to the trench bottom prior to the preparation of the bedding. If the ground water cannot be maintained below the bed, filter cloth should be used to surround the bed and the pipe zone to prevent migration. In this case gravel or crushed stone should be used as bedding and backfill material.

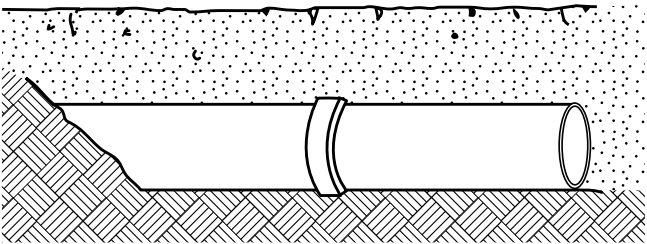

Figure 5 – Correct bedding

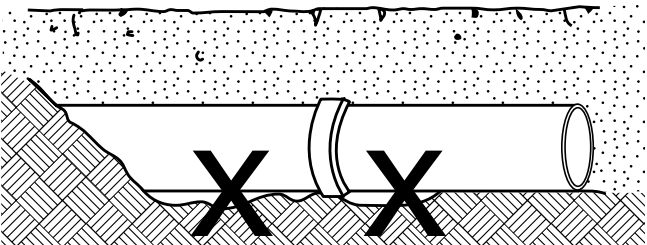

Figure 6 – Incorrect bedding

3.3 Backfilling and Compaction

It is very important that the backfilling and compaction are done in the right way.

The haunching material in the area between the bedding and the underside of the pipe should be worked in and compacted before placing the remainder of the backfill (**see figure 7** →).

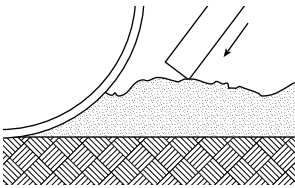

Figure 7 – Proper haunch backfill

Backfilling is done in layers of usually 200-300 mm for SC1 and SC2 material and 100-200 mm for SC3 (see [table 1](#) →).

Backfill Soil Type	Hand-operated Impact Compactor	Hand-operated Vibrating Plate Recommendations	
Type SC1		300 mm	Two passes should provide good paction
Type SC2		200 - 250 mm	Two to four passes, depending on height and required density
Type SC3	100 - 200 mm		Layer height and number of passes are dependent on required density. Use at or near optimum moisture content. Check compaction.
Type SC4	100 - 150 mm		May require considerable compaction energy. Control moisture content to be at optimum. Verify compaction.

Table 1 – Compacting above the pipe should be done in accordance with the following table

Equipment Weight kg	Minimum Pipe Cover*(mm)	
	Tamped	Vibrated
< 50	-	-
50 - 100	250	150
100 - 200	350	200
200 - 500	450	300
500 - 1000	700	450
1000 - 2000	900	600
2000 - 4000	1200	800
4000 - 8000	1500	1000
8000 - 12000	1800	1200
12000 - 18000	2200	1500

*It may be necessary to begin with higher cover so that, as compaction is achieved, the cover will not be less than the minimum

Table 2 – Minimum cover for compacting above pipe

In trenches where sheet piles are used, remove the sheeting in steps and direct compaction of pipe-zone backfill against the trench wall provides the best support to the pipe. Make sure there are no voids or lack of backfill between the outside of the sheeting and the native soil up to at least 1 m above the pipe crown.

Use only SC1 or SC2 between the temporary sheeting and the native soil compacted to at least 90% SPD.

3.4 Concrete encasement and Floatation

The concrete must be poured in stages allowing sufficient time between layers for the cement to set and no longer exert buoyant forces. The maximum lift heights are shown in the table below.

SN	Maximum lift
2500	Larger of 0.3 m or DN/4
5000	Larger of 0.45 m or DN/3
10000	Larger of 0.6 m or DN/2

Table 3 – Maximum Concrete Pour Lift

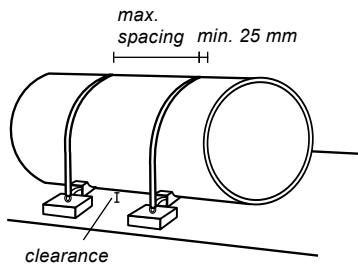

Figure 8 – Pipe anchoring

During pouring the concrete, or in order to prevent floatation, the pipe must be restrained against movement. This is usually done by strapping over the pipe to a base slab or other anchors. The straps are flat with a minimum of 25 mm width and strong enough to withstand the floatation forces.

Maximum spacing of straps is as shown in **table 4**.

DN	Maximum Spacing (m)
< 200	1.5
200 – 400	2.5
500 – 600	4.0
700 – 900	5.0
≥ 1000	6.0

Table 4 – Maximum strap spacing

The buoyancy must be checked in cases of low coverage and high groundwater levels, or in flood plains.

DN	h min [m] for security S = 1.1
100	0.07
300	0.20
600	0.37
1000	0.62
2000	1.25
2400	1.50

Table 5 – Minimum coverage of empty pipes for groundwater to top edge of site

3.5 Thrust Restraints and Connection to Rigid Structures

When the pipeline is pressurized, unbalanced forces occur at change of direction. These forces are usually restrained by thrust blocks. Thrust blocks are required for the fittings when the line pressure exceeds 1 bar (100 kPa). It is not necessary to encase nozzle connections in concrete. Nozzles are defined as follows:

1. Nozzle diameter ≤ 300 mm
2. Header diameter ≥ 3 times nozzle diameter

For all connections to rigid structures action must be taken to minimize the development of high discontinuity stresses in the pipe. Angular deflection and misalignment at joints close to thrust blocks shall be avoided during installation. Two options are available:

1 Standard

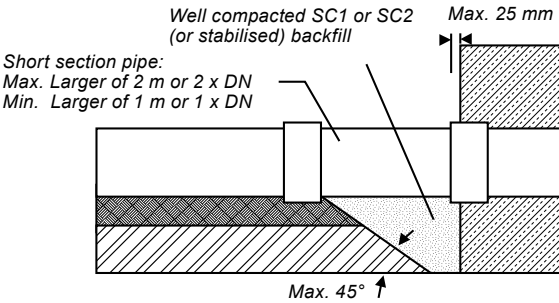

Figure 9 – Standard connection – Coupling cast in concrete

2 Alternate

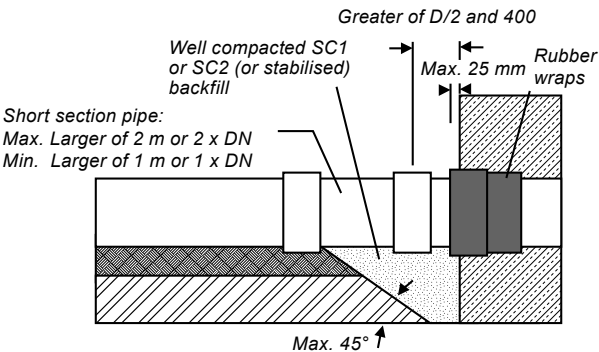

Figure 10 – Alternate connection – Rubber wrap encased in concrete

3.6 Jointing Pipes, Cutting, Laminates

For small diameter pipes to DN 300, the pipes can be connected using a crowbar with a wooden block as padding as shown in **figure 11** →. For larger diameters, coupling can be done using “Come along jacks” and clamps as shown in **figures 12 and 13** →.

The lubricant supplied should be applied thinly to the spigot end using a clean cloth or a brush. Insertion of the spigot ends of the pipe should be limited to the home-line and any damage to the pipe and coupling avoided.

For field adjustments use only pipes marked as “Adjustment Pipe”. After cutting, these pipes with circular saw with a diamond coated blade, clean the surface in the jointing area, sand smooth any rough spots and with a grinder bevel grind the pipe end. No further grinding is needed. The inside edge of an adjustment pipe is chamfered after field cutting.

To make a laminated connection, the pipe surface must be dry and free of dust or grease. The joint is made from glass fibre reinforcements impregnated with resin. The outside temperature should be at least approx. 15 °C and the work should be carried out by qualified personnel.

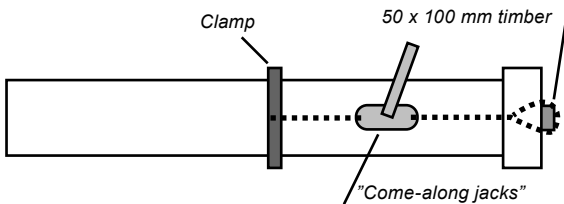

Figure 11 – Mounting of coupling on pipe

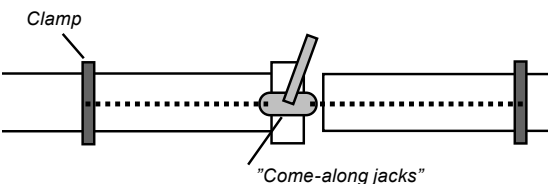

Figure 12 – Pipe joining using clamps

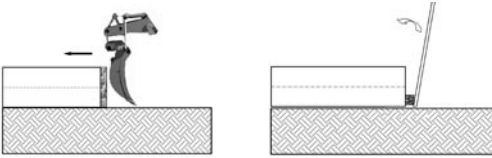

Figure 13 – Mounting with excavator shovel or crowbar.

Approximate assembly force in tonnes = (DN in mm/1000) x 2

3.7 Angular deflection of Flowtite Couplings

The maximum horizontal or vertical bend in any coupling must not exceed the values in **tables 6 and 7**.

Nom. Pipe Diameter (mm)	Pressure (PN) in bars			
	Up to 16	20	25	32
DN ≤ 500	3.0	2.5	2.0	1.5
500 < DN ≤ 900	2.0	1.5	1.3	1.0
900 < DN ≤ 1800	1.0	0.8	0.5	0.5
DN > 1800	0.5	NA	NA	NA

Table 6 – Bend in degrees per dual bush coupling

Angle of Deflection (deg)	Maximum Offset (mm)			Radius of Curvature (m)		
	Pipe length			Pipe length		
	3 m	6 m	12 m	3 m	6 m	12 m
3.0	157	314	628	57	115	229
2.5	136	261	523	69	137	275
2.0	105	209	419	86	172	344
1.5	78	157	313	114	228	456
1.3	65	120	240	132	265	529
1.0	52	105	209	172	344	688
0.8	39	78	156	215	430	860
0.5	26	52	104	344	688	1376

Table 7 – Offset and curve radius

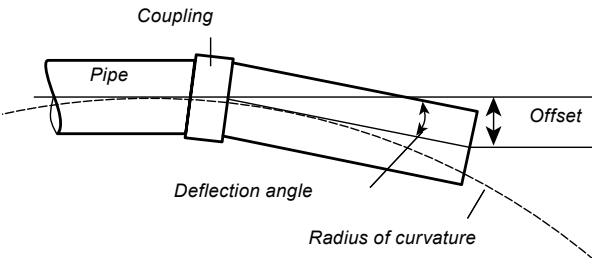

Figure 14 – Flowtite coupling, angular deflection

3.8 Cleaning Sewer and Waste Water Pressure Pipes (FS and FPS)

The following guidelines should be adhered to when performing high-pressure cleaning:

- 1 Observe a maximum pressure in the nozzle of 120 bar. Due to the smooth interior surface of GRP pipes, proper cleaning and the removal of blockages is generally possible well below this pressure value.
- 2 All-round spraying nozzles are to be preferred. In particular rotating spray nozzles and sewer fraises, as well as aggressive nozzles with a high damage potential are to be avoided.
- 3 The impact angle of the spray jet should not exceed 30 degrees. Impact angles of less than 20 degrees are sufficient for GRP pipe material.
- 4 The number of spray openings should be 6 to 8 and the diameter of the openings should be at least 2.4 mm.
- 5 The outside surface of the nozzle unit must be smooth and the weight of the nozzle must not be greater than 4.5 kg. The length of the nozzle in relation to the 4.5 kg must not be less than 17cm. Lighter nozzles (around 2.5 kg, see figure above.) are to be used especially for smaller nominal widths (DN 100 – DN 800).
- 6 Extreme entry and exit speeds (> 30 m/min) are to be absolutely avoided.
- 7 The use of sliding rinsing or cleaning carriages facilitates gentle cleaning.
- 8 Localised flaking of the abrasion protection surface does not affect the function of the pipe system and is therefore not considered to be a material change.

For further information, please contact the pipe manufacturer.



4. POST INSTALLATION

Deflection measurements in each pipe are recommended as a good check on pipe installation quality. Pipes with initial deflection exceeding the acceptable values must be reinstalled (**see table 8** →).

	Deflection % of Diameter
Large Diameter (DN ≥ 300)	3.0
Small Diameter (DN ≤ 250)	2.5

Table 8 – Allowable vertical deflection

Calculate the % deflection as follows:

$$\% \text{ Deflection} = \frac{\text{Actual I.D.} - \text{Installed Vertical I.D.}}{\text{Actual I.D.}} \times 100$$

Actual I.D. may be verified or determined by measuring the diameters of a pipe not yet installed laying loose (no pipes stacked above) on a reasonably plane surface.

Calculate as follows:

$$\text{Actual I.D.} = \frac{\text{Vertical I.D.} + \text{Horizontal I.D.}}{2}$$

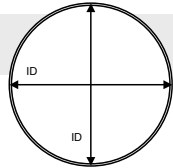

Figure 15

5. FIELD HYDRO-TESTING

Good practice would be to not exceed pipe testing with installation by more than approximately 1000 meters.

1 Prior to the test check the following:

- Initial pipe deflection within the acceptable limit
- Joints assembled correctly
- System restrained in place
- Flange bolts are torqued per instructions
- Backfilling completed
- Valves and pumps anchored
- Backfill and compaction near structures and at closure pieces has been properly carried out

2 Filling the line with Water – Open valves and vents, so that all air is expelled from the line during filling, and avoid pressure surges.

- 3 Pressurize the line slowly. Considerable energy is stored in a pipeline under pressure, and this power should be respected.
- 4 Ensure the gauge location will read the highest line pressure or adjust accordingly. Locations lower in the line will have higher pressure due to additional head.
- 5 Ensure the maximum test pressure does not exceed $1.5 \times PN$. Normally the field test pressure is either a multiple of the operating pressure or the operating pressure plus a small incremental amount. However, in no case should the maximum field test pressure exceed $1.5 \times PN$.
- 6 If after a brief period for stabilization the line does not hold constant pressure, ensure that thermal effect (a temperature change), system expansion or entrapped air is not the cause. If the pipe is determined to be leaking and the location is not readily apparent, the following methods may aid discovery of the problem source:
 - Check flange and valve areas.
 - Check line tap locations.
 - Use sonic detection equipment.
 - Test the line in smaller segments to isolate the leak.

An alternate leak test for gravity pipe (PN 1 bar) systems may be conducted with air pressure instead of water. In addition to routine care, normal precautions and typical procedures used in this work, the following suggestions and criteria should be noted:

- 1 As with the hydrotest, the line should be tested in small segments, usually the pipe contained between adjacent manholes.
- 2 Ensure the pipeline and all materials, stubs, accesses, drops, etc. are adequately capped or plugged and braced against the internal pressure.
- 3 Slowly pressurize the system to 0.24 bar. The pressure must be regulated to prevent over pressurisation (maximum 0.35 bar).
- 4 Allow the air temperature to stabilize for several minutes while maintaining the pressure at 0.24 bar.
- 5 During this stabilization period, it is advisable to check all plugged and capped outlets with a soap solution to detect

leakage. If leakage is found at any connection, release the system pressure, seal the leaky cap(s) or plug(s) and begin the procedure again at Step 3.

- 6 After the stabilization period, adjust the air pressure to 0.24 bar and shut-off or disconnect the air supply.
- 7 The pipe system passes this test if the pressure drop is 0.035 bar or less during the time periods given in **Table 9**.
- 8 Should the section of line under test fail the air test acceptance requirements, the pneumatic plugs can be coupled fairly close together and moved up or down the line, repeating the air test at each location, until the leak is found. This leak location method is very accurate, pinpointing the location of the leak to within one or two metres. Consequently, the area that must be excavated to make repairs is minimized, resulting in lower repair costs and considerable saved time.

! Caution: CONSIDERABLE ENERGY IS STORED IN A PIPELINE UNDER PRESSURE. THIS IS PARTICULARLY TRUE WHEN AIR (EVEN AT LOW PRESSURES) IS THE TEST MEDIUM. TAKE GREAT CARE TO BE SURE THAT THE PIPELINE IS ADEQUATELY RESTRAINED AT CHANGES IN LINE DIRECTION AND FOLLOW MANUFACTURERS' SAFETY PRECAUTIONS FOR DEVICES SUCH AS PNEUMATIC PLUGS.

! Note: This test will determine the rate at which air under pressure escapes from an isolated section of the pipeline. It is suited to determining the presence or absence of pipe damage and/or improperly assembled joints.

Diameter (mm)	Time (min.)	Diameter (mm)	Time (min.)
100	2.50	1000	25.00
150	3.75	1100	27.50
200	5.00	1200	30.00
250	6.25	1300	32.50
300	7.75	1400	35.00
350	8.75	1500	37.50
400	10.00	1600	40.00
500	12.50	1800	45.00
600	15.00	2000	50.00
700	17.50	2200	55.00
800	20.00	2400	60.00
900	22.50		

Table 9 – Test time - Field Air Test

6. ASSEMBLY INSTRUCTIONS FOR GRP SHAFT CONSTRUCTIONS

The simple assembly and the problem-free installation of GRP shaft constructions for waste water disposal as well as potable water supply represent a considerable advantage.

Due to the light weight of the construction elements, heavy lifting equipment (truck-mounted crane) is generally unnecessary to a shaft diameter of DN 2000.

The shaft elements can therefore be installed in the most cases using the same equipment as for the excavation. The devices required for installation are commercially available cable hangers. Installation elements such ring eyes and uni-head lifters (**see figures 16 and 17** →), are provided with the delivered constructions.

For the foundations or the bedding of the shaft constructions it is a matter of principle that the shaft and the pipes to be attached should be embedded in the same manner to avoid different settling of shaft constructions and pipes.

Any necessary pipe abutments to absorb pressure surges or pipeline forces are not directly fixed to the shaft construction. The concrete abutments required are installed outside the construction in the appropriate places.



Figure 16 – Ring eye



Figure 17 – Uni-head lifter

6.1 Installation instructions for GRP shaft constructions, vertical

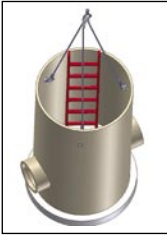

Figure 18 – Gutter shaft, hanging

If the sub grade can carry a load, a clean bedding layer of the same material as the pipe bedding is required. Non load carrying sub grades require a concrete foundation of at least 15 cm. The shaft constructions to 3.5 t are fitted with 3 ring eyes M 24, to enable them to be hung with the appropriate cable hangers (see figures 18 and 19 →).

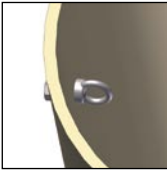

Figure 19 – Fitting ring eye

The tilt angle must not be lower than 60 degrees. Shaft constructions over 3.5 t are fitted with ring eyes M 30.

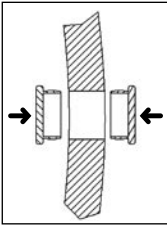

Figure 20 – Closing the assembly holes

After moving the construction, the ring eyes are to be removed, the assembly holes are to be hammered closed from the inside and the outside using the plastic caps supplied (see figure 20 →).

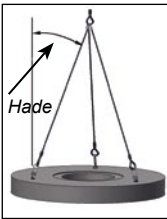

Figure 21 – Reinforced concrete cover plate

The reinforced concrete cover plate for the shaft construction is fitted with a uni-head for hanging and is supplied with uni-head lifters (see figure 21 →).

6.2 Installation instructions for GRP shaft constructions, horizontal

To lay the shaft constructions, textile cable slings of the appropriate length and strength should be used. If the groundwater level and static calculations mean that buoyancy security is necessary, the shaft construction can be pre-fitted with stainless steel anchors and the required security against floating can be achieved by the use of site-mixed concrete.

This abridgment is intended as a quick reference only. All values listed in the product specifications are nominal. Unsatisfactory product results may occur due to environmental fluctuations, variations in operating procedures, or interpolation of data. We highly recommend that any personnel using this data have specialised training and experience in the application of these products and their normal installation and operating conditions.

The engineering staff should always be consulted before any of these products are installed to ensure the suitability of the products for their intended purpose and applications. We hereby state that we do not accept any liability, and will not be held liable, for any losses or damage which may result from the installation or use of any products listed in this handbook as we have not determined the degree of care required for product installation or service. We reserve the right to revise this data, as necessary, without notice.

We welcome comments regarding this condensed version.



Flowtite Technology AS

P.O. Box 2059

3202 Sandefjord

Norway

Phone: + 47 33 44 91 58

Fax: + 47 33 46 26 17

info@amiantit.com

www.flowtite.com

www.amiantit.com