



FLOWTITE

Installation Guide for Buried Pipes – AWWA



AMIAANTIT PIPE SYSTEMS

1	Introductory Information	4
1.1	Foreword	4
1.2	Soil-pipe system	4
1.3	Field Technician	5
1.4	Safety	5

2	Shipping, Handling and Storage	6
2.1	Inspecting Pipe	6
2.2	Repairing Pipe	6
2.3	Unloading and Handling Pipe	6
2.4	Site Pipe Storage	7
2.5	Storing Gaskets and Lubricant	7
2.6	Transporting Pipe	8
2.7	Handling Nested Pipes	8

3	Pipe Installation Procedure	9
3.1	Standard Trench	9
3.2	Pipe Bedding	9
3.3	Backfill Materials	10
3.4	Installation types	10
3.5	Backfilling Pipe	11
3.6	Compaction above Pipe	12
3.7	Pipe Deflections	12

4	Joining Pipes	13
4.1	FLOWTITE double Bell Couplings	13
4.2	Locked Joints	15
4.3	Flanged Joints	15
4.4	Layup Joint	16
4.5	Other Joining Methods	17

5	Thrust Restraints, Concrete Encasement and Connections to Rigid Structures	18
5.1	Concrete Encasement	19
5.2	Connections to Rigid Structures	20
5.3	Casings (Tunnels)	22
5.4	Concrete-wall Connections	22

6	Field Adjustments	24
6.1	Length Adjustment	24
6.2	Field Closures with FLOWTITE Couplings	24
6.3	Field Closures with Non-FLOWTITE Couplings	25

7 Other Installation Procedures and Considerations	26
7.1 Multiple Pipes in Same Trench.....	26
7.2 Cross-Overs.....	26
7.3 Unstable Trench Bottom.....	26
7.4 Flooded Trench.....	27
7.5 Use of Trench Supports.....	27
7.6 Trench Construction in Rock.....	27
7.7 Inadvertent Over-Excavation.....	28
7.8 Installation of Pipes on Slopes (Parallel).....	28
8 Accommodating Valves and Chambers	29
8.1 Anchoring In-Line Valves.....	29
8.2 Air and Vacuum Valves.....	32
8.3 Clean Out and Scour Valves.....	33
9 Post-Installation	34
9.1 Checking the Installed Pipe.....	34
9.2 Correcting Over-Deflected Pipe.....	34
9.3 Field Hydrotesting.....	35
9.4 Field Joint Tester.....	36
9.5 Field Air Test.....	36
10 Alternate Installations	37
10.1 Wide Trench.....	37
10.2 Cement Stabilised Backfill.....	37
Appendix	39
Appendix AWWA M 45 or ATV 127	

1 Introductory Information

1.1 Foreword

This document is part of the Flowtite documentation for the users of Flowtite products. It is to be used in connection with the Flowtite Product Guide and is intended to assist the installer in understanding the requirements and procedures for the successful handling and buried installation of FLOWTITE[®], pipe.

The appendices may serve as a helpful source of data for owner's engineers.

This document mainly addresses the usual circumstances that may be encountered in the field; unique situations requiring special considerations are not addressed and should be resolved in cooperation with the supplier.

Installations other than direct bury, such as trenchless, sub-aqueous or above-ground, are not discussed in this manual. Consult the supplier for suggested procedures and limitations in these cases.

Most importantly, this installation guide is not meant to replace common sense, good engineering requirements and judgement, applicable laws, safety or environmental or other regulations or local ordinances, nor the specifications and instructions of the owner and/or the owner's engineer, who is/are the final authority on each job. Should any conflicting information in this brochure create doubts as to how to proceed properly please consult the supplier and the owner's engineer to obtain assistance.

The installation procedures outlined in this Installation Guide and the suggestions of the Field Technicians, when carefully followed, will help with the thorough execution of a proper, long-lasting installation. Consult the supplier on any questions or when variations from this installation guide are being considered.

! **Note:** These installation instructions are based on the structural design procedures of AWWA M 45, but are also valid for ATV 127. The main text is essentially aligned with AWWA, while the appendices contain information that is specific to either ATV or AWWA.

1.2 Soil-pipe system

The versatility of soil behaviour, along with the strength and flexibility of Flowtite pipes offers a unique potential for soil-structure interaction that allows optimum system performance. The glass fibre reinforcement is placed where needed in the pipe for flexibility and strength, while trench geometry, along with selection, placement and compaction of backfill ensures the integrity of the system.

Broadly there are two sets of loads that the pipe is subject to:

- 1** external loads resulting from overburden, surface loads and traffic, creating bending stresses in the pipe wall
- 2** internal pressure creating hoop stresses in the pipe and unbalanced thrust creating axial stresses.

The flexibility of FLOWTITE pipe combined with the natural structural behaviour of soils provide an ideal combination for transferring vertical load. Unlike stiff pipes, which would break under excessive vertical load, the pipe's flexibility combined with its high strength, allow it to bend and redistribute the load to the surrounding soil. The deflection of the pipe serves as an indicator of the stresses generated in the pipe and the quality of the installation. Hoop stresses are resisted by placing continuous glass fibre reinforcement circumferentially in the pipe wall. The amount of reinforcement is dictated by the pressure level and determines the pressure class of the pipe.

Unbalanced thrust is usually most economically resisted through thrust blocks that transfer the thrust by direct bearing to the native soil. The standard FLOWTITE pipe is therefore not required to transfer axial thrust and the amount of reinforcement in the pipe wall in the axial direction is limited to secondary effects. Consequently the joints are not required to transfer axial load, but allow for movement of the pipe within the joint due to temperature and Poisson's effect.

In some cases thrust-blocks may be undesirable due to their weight, lack of space, or other reasons. In such cases enough reinforcement is placed in the pipe wall in the axial direction to carry the direct thrust. Restraint joints for such systems are designed to carry the full axial thrust, and the thrust is transferred to the surrounding soil through direct bearing and friction.

1.3 Field Technician

The supplier can, at the request of the purchaser and within the terms of the agreement between the purchaser and the supplier, provide a Field Technician. The Field Technician can advise the purchaser and/or the Installer to help him achieve a satisfactory pipe installation. It is recommended that “on the job” field service should be engaged in the initial stage of installation and may continue periodically throughout the project. The service may range from continuous (essentially full time) to intermittent depending on agreement between purchaser and supplier.

1.4 Safety

Glass-reinforced polyester (GRP) pipe, like virtually all pipe made with petrochemicals, can burn and is therefore not recommended for use in applications which are exposed to intense heat or flames. During installation, care must be taken to avoid exposure of the pipe to welder’s sparks, cutting-torch flames or other heat/flame/electrical sources which could ignite the pipe material. This precaution is particularly important when working with volatile chemicals in making layup joints, repairing or modifying the pipe in the field.

Operations in trenches are carried out in potentially hazardous conditions. Where appropriate shore, sheet, brace, slope or otherwise support the trench walls to protect any person in the trench. Take precautions to prevent objects falling into the trench, or its collapse caused by the position or movements of adjacent machinery or equipment, while the trench is occupied. Excavated material should be deposited in a safe distance from the edge of the trench, and the proximity and height of the soil bank should not be allowed to endanger the stability of the excavation.

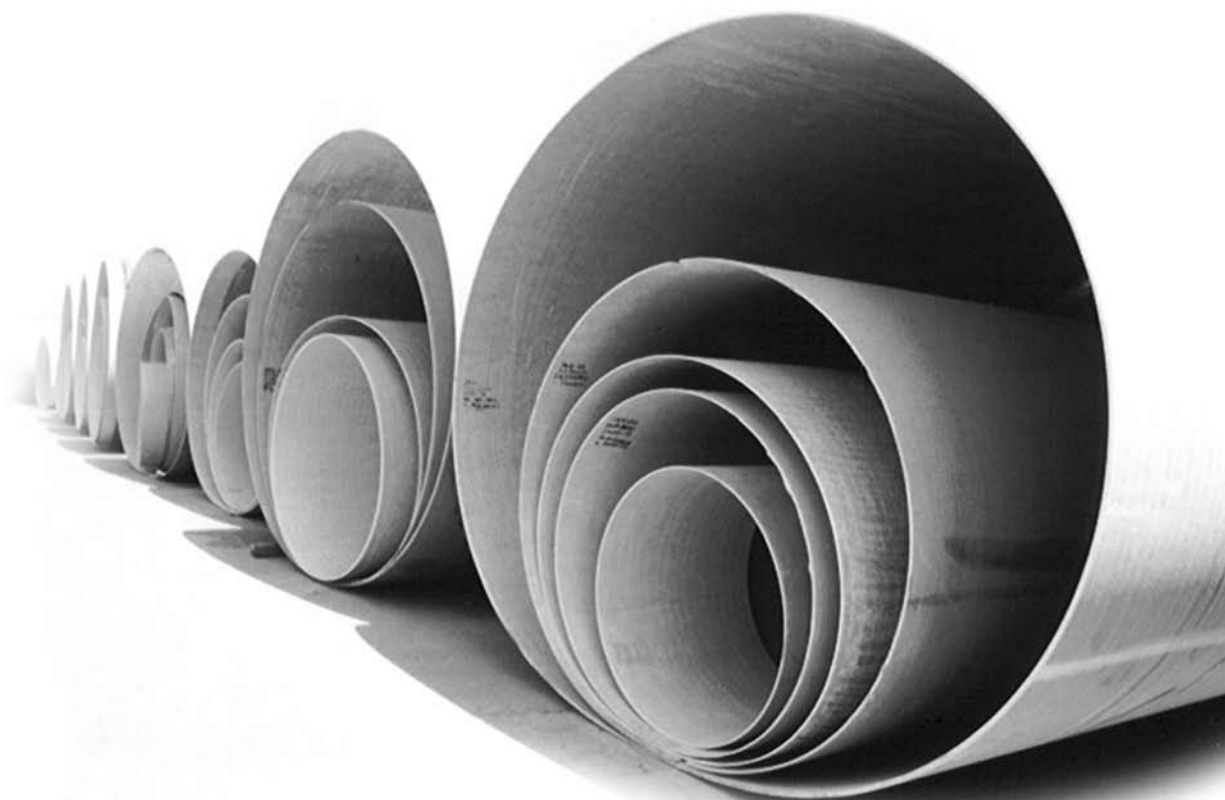

2 Shipping, Handling and Storage

2.1 Inspecting Pipe

All pipes should be inspected upon receipt at the job site to insure that no damage has occurred in transit. Depending on length of storage, amount of job site handling and other factors that may influence the pipes condition, it is recommended that the pipe be re-inspected just prior to installation.

Inspect the shipment upon delivery, as follows:

- 1 Make an overall inspection of the load. If the load is intact, ordinary inspection while unloading will normally be sufficient to make sure the pipe has arrived without damage.
- 2 If the load has shifted or indicates rough treatment, carefully inspect each pipe section for damage. Generally, an exterior inspection will be sufficient to detect any damage. When pipe size permits, an interior inspection of the pipe surface at the location of an exterior scrape may be helpful to determine if the pipe is damaged.
- 3 Check the quantity of each item against the bill of lading.
- 4 Note on the bill of lading any transit damage or loss and have the carrier representative sign your copy of the receipt. Claims against the carrier should be in accordance with their instructions.
- 5 If any imperfections or damage is found, segregate the affected pipes and contact the supplier.

Do not use pipe that appears damaged or defective.

2.2 Repairing Pipe

Normally, pipes with minor damage can be repaired quickly and easily at the job site by a qualified individual. If in doubt about the condition of a pipe, do not use it.

The Field Technician can help you determine whether repair is required and whether it is possible and practical. Repair designs can vary greatly due to pipe thickness, wall composition, application, and the type and extent of the damage. Therefore do not attempt to repair a damaged pipe without consulting the supplier first. Repairs must be made by a trained repair technician. Improperly repaired pipes may not perform as intended.

2.3 Unloading and Handling Pipe

Unloading the pipe is the responsibility of the customer. Be sure to maintain control of the pipe during unloading. Guide ropes attached to pipes or packages will enable easy manual control when lifting and handling. Spreader bars may be used when multiple support locations are necessary. Do not drop, impact, or bump the pipe, particularly at pipe ends.

Single Pipes

When handling single pipes, use pliable straps, slings or rope to lift. Do not use steel cables or chains to lift or transport the pipe. Pipe sections can be lifted with only one support point (*Figure 2-1*) although two support points placed as in *Figure 2-2* is the preferred method for safety reasons as it makes the pipe easier to control. Do not lift pipes using hooks at pipe ends or by passing a rope, chain or cable through the section end to end. See Appendix A for approximate weights of standard pipes and couplings.

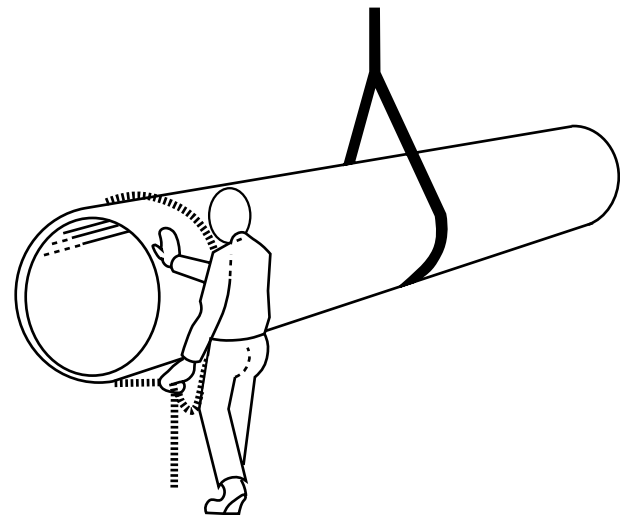

Figure 2-1 Lifting pipe at one support point

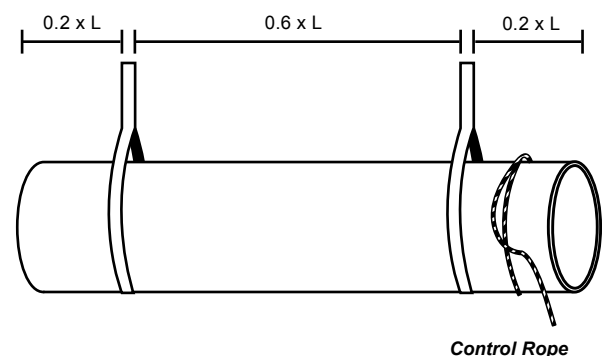

Figure 2-2 Lifting pipe at two support points

Unitized Loads

Unitized loads may be handled using a pair of slings as shown in **Figure 2-3**. Do not lift a non-unitized stack of pipes as a single bundle.

Non-unitized pipes must be unloaded and handled separately (one at a time).

If at any time during handling or installation of the pipe, any damage such as a gouge, crack or fracture occurs, the pipe should be repaired before the section is installed.

Contact the supplier for inspection of damaged and for recommendation of repair method or disposal.

See section 2.2 [→](#).

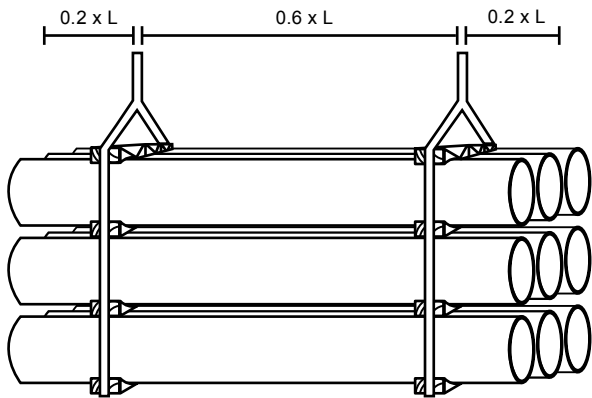

Figure 2-3 Lifting unitized package

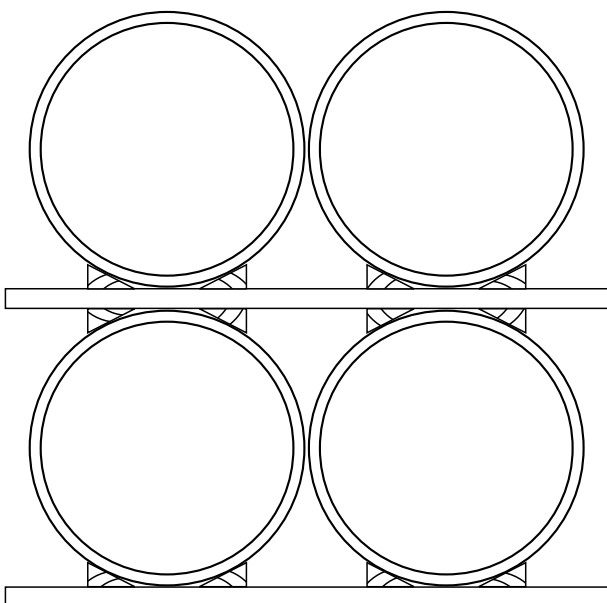

Figure 2-4 Storing pipe

2.4 Site Pipe Storage

It is generally advantageous to store pipe on flat timber to facilitate placement and removal of lifting slings around the pipe.

When storing pipe directly on the ground, be sure that the area is relatively flat and free of rocks and other potentially damaging debris. Placing the pipe on mounds of backfill material has been found to be an effective way of site storing the pipe. All pipes should be chocked to prevent rolling in high winds.

If it is necessary to stack pipes, it is best to stack on flat timber supports (minimum width of 75 mm) at quarter point with chocks (see **Figure 2-4**). If it is available, use the original shipping dunnage.

Insure the stack will be stable for conditions such as high winds, uneven storage surface or other horizontal loads. If strong winds are anticipated consider using ropes or slings to tie pipes down. Maximum stack height is approximately 3 metres.

Bulges, flat areas or other abrupt changes of pipe curvature are not permitted. Storing of pipes outside of these limitations may result in damage to the pipes.

2.5 Storing Gaskets and Lubricant

Rubber ring gaskets, when shipped separately from the couplings, should be stored in the shade in their original packing and should not be exposed to sunlight except during the pipe joining. Also, the gaskets must be protected from exposure to greases and oils which are petroleum derivatives, and from solvents and other harmful substances.

Gasket lubricant should be carefully stored to prevent damage. Partially used buckets should be resealed to prevent contamination of the lubricant. If temperatures during installation are below 5°C , gaskets and lubricant should be sheltered until used.

2.6 Transporting Pipe

Support all pipe sections on flat timbers, spaced at maximum 4 metres (3 metres for diameter \leq DN250), with a maximum overhang of 2 metres. Chock the pipes to maintain stability and separation. Avoid abrasion.

Maximum stack height is approximately 2.5 metres. Strap pipe to the vehicle over the support points using pliable straps or rope (**Figure 2-5**). Never use steel cables or chains without adequate padding to protect the pipe from abrasion. Bulges, flat areas or other abrupt changes of curvature are not permitted. Transport of pipes outside of these limitations may result in damage to the pipes.

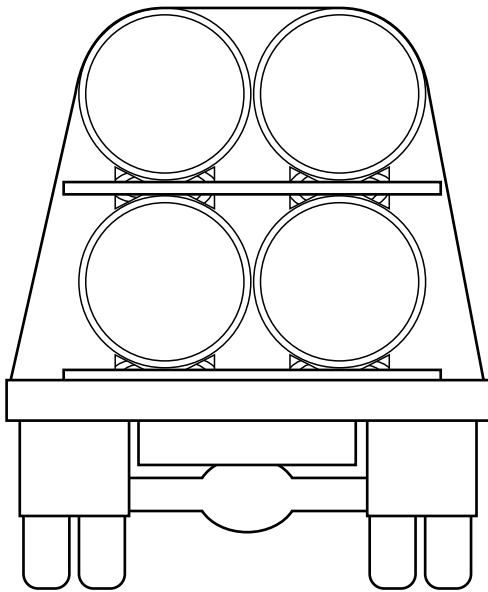

Figure 2-5 Transporting pipe

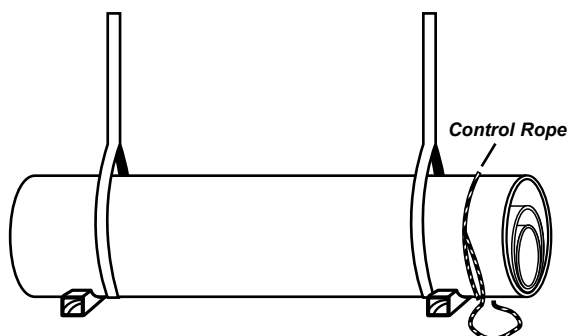

Figure 2-6 Double support point for nested pipes

2.7 Handling Nested Pipes

Pipes may be nested (smaller diameter pipes inside of larger sizes). These pipes generally have special packaging and may require special procedures for unloading, handling, storing and transporting. Special measures, if required, will be carried out by the pipe supplier prior to shipment. However, the following general procedures should always be followed:

- 1 Always lift the nested bundle using at least two pliable straps (**Figure 2-6**). Limitations, if any, for spacing between straps and lifting locations will be specified for each project. Insure that the lifting slings have sufficient capacity for the bundle weight. This may be calculated from the approximate pipe weights given in Appendix H.
- 2 Nested pipes are usually best stored in the transport packaging. Stacking of these packages is not advised unless otherwise specified.
- 3 Nested pipe bundles can only be safely transported in the original transport packaging. Special requirements, if any, for support, configuration and/or strapping to the vehicle will be specified for each project.
- 4 Package removal and de-nesting of the inside pipe(s) is best accomplished at a de-nesting station. Inside pipes, starting with the smallest size may be removed by lifting slightly with an inserted padded boom to suspend the section and carefully move it out of the bundle without damaging the other pipes (**Figure 2-7**). When weight, length and/or equipment limitations preclude the use of this method, procedures for sliding the inside pipe(s) out of the bundle will be recommended for each project.

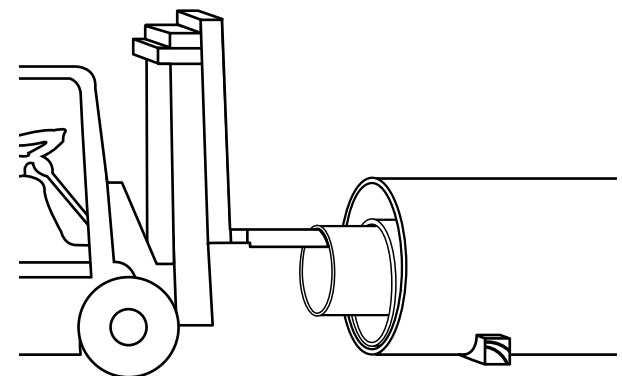

Figure 2-7 De-nesting with padded boom on forklift truck

3 Pipe Installation Procedure

- 01
- 02
- 03
- 04
- 05
- 06
- 07
- 08
- 09
- 10
- app.

The type of installation procedure appropriate for FLOWTITE pipe varies with pipe stiffness, cover depth, trench width, native soil characteristics, surcharge loads and backfill materials.

The native material must adequately confine the pipe zone backfill to achieve proper pipe support. The following installation procedures are intended to assist the installer in achieving a proper pipe installation

The static calculation method ATV 127 is frequently used. As an aid, the following is the correlation between the backfill soil stiffness categories of these instructions and the ATV 127 soil groups, G1 to G4:

SC1 corresponds to the best of the G1 soils. SC2 corresponds to the G1 soils and the best of the G2 soils.

SC3 corresponds to the weaker G2 soils and the best of the G3 soils. SC4 corresponds to the weaker G3 soils and the best of the G4 soils.

3.1 Standard Trench

Figure 3-1 shows typical trench dimensions. Dimension "A" must always be wide enough to allow for adequate space to ensure proper placement and compaction of backfill in the haunch region. Dimension "A" must also be wide enough to safely operate compaction equipment without damaging the pipe. Typically dimension "A" is a minimum of 0.4 DN, except for very small diameters.

For larger diameter pipes a smaller value for "A" may be adequate depending on the native soil, backfill material and compaction technique. As an example for native soil groups 1, 2 and 3 and backfill materials SC1 and SC2 which require limited compaction effort, a narrower trench could be considered.

Note: Where rock, hard pan, soft, loose, unstable or highly expansive soils are encountered in the trench bottom, it may be necessary to increase the depth of the bedding layer to achieve uniform longitudinal support.

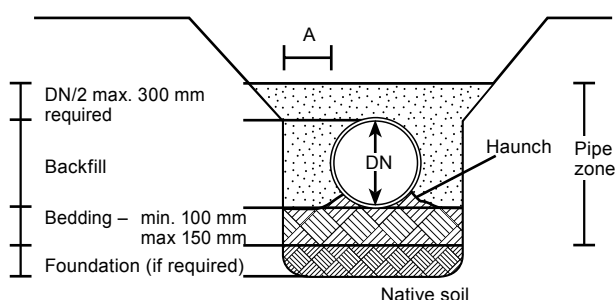

Figure 3-1 Pipe backfill nomenclature

3.2 Pipe Bedding

The bedding should be placed over a firm, stable trench bottom so as to provide proper support. The finished bed must provide a firm, stable and uniform support for the pipe barrel and any protruding feature of its joint.

Provide 100 - 150 mm of bedding below the barrel and 75 mm below the coupling. For soft or unstable trench bottom, an additional foundation may be needed to achieve firm support for the bedding, see section 7.3 →.

The bedding material may need to be imported to provide proper gradation and pipe support. The recommended materials for bedding are SC1 or SC2. To determine if the native material is acceptable as a bedding material, it should meet all of the requirements of the pipe zone backfill. This determination must be made constantly during the pipe installation process because native soil conditions may vary and change suddenly along the length of a pipeline.

The bed must be over-excavated at each joint location to ensure that the pipe will have a continuous support and does not rest on the couplings. The coupling area must be properly bedded and backfilled after the joint assembly is completed. See **Figure 3-2** and **Figure 3-3** for proper and improper bedding support.

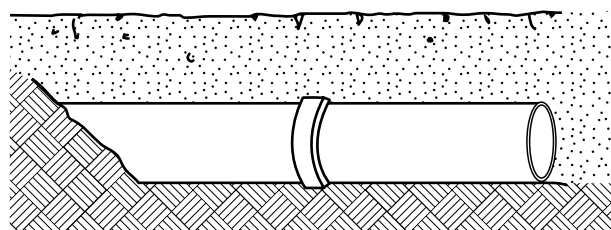

Figure 3-2 Proper bedding support

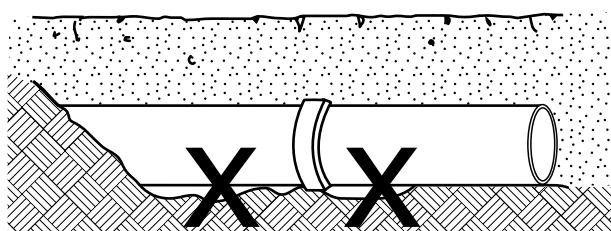

Figure 3-3 Improper bedding support

3.3 Backfill Materials

Table 3–1 groups backfill materials into categories. SC1 and SC2 backfill soils are the easiest to use and require the least compaction effort to achieve a given level of relative compaction.

Regardless of the backfill grouping and whether the backfill soil is imported or not the following general restrictions apply:

- 1 For the maximum particle size and stone size the limits given in **Table 3–2** must be respected.
- 2 No soil clumps greater than two times the maximum particle size.
- 3 No frozen material.
- 4 No organic material.
- 5 No debris (tires, bottles, metals, etc.)

Backfill Soil Group	Description of Backfill Soils
SC1	Crushed rock with < 15% sand, maximum 25% passing the 10 mm sieve and maximum 5% fines
SC2	Clean, coarse-grained soils with < 12% fines
SC3	Clean, coarse-grained soils with 12% or more fines Sandy or fine-grained soils with less than 70% fines
SC4	Fine grained soils with more than 70% fines

(See Appendix D for further clarification and Appendix G for definitions)

Table 3–1 Backfill materials

Maximum particle size in the pipe zone (up to 300 mm over the pipe crown):

DN	Max. Size (mm)
≤ 450	13
500 - 600	19
700 - 900	25
1000 - 1200	32
≥ 1300	40

Table 3–2 Maximum Particle Size

The backfill above the pipe zone may be made with excavated material with a maximum particle size of up to 300 mm providing there is at least 300 mm cover over the pipe. Stones larger than 200 mm should not be dropped on the 300 mm layer covering the pipe crown from a height greater than 2 metres.

3.4 Installation types

Two standard backfilling configurations are recommended (**Figure 3–4 and Figure 3–5**). The selection of type depends on the native soil characteristics, the backfill materials, required depth of burial, surcharge conditions, pipe stiffness and the pipe operating conditions. The Type 2, “split” configuration is generally more utilized for applications of lower pressure (PN ≤ 10 bar), light duty traffic loading and limited negative pressure (vacuum) requirement.

Installation Type 1

- Construct the pipe bed following the guidelines of section 3.2 →.
- Backfill the pipe zone (to 300 mm) over the pipe crown with the specified backfill material compacted to the required compaction level (see Appendix B →).
- ! **Note:** For low pressure (PN ≤ 1 bar) applications without traffic load the requirement to compact the 300 mm over the pipe crown may be waived.

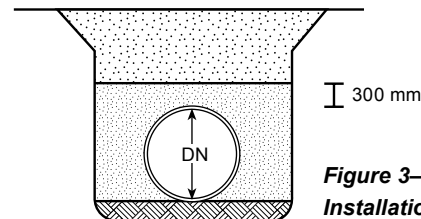

Figure 3–4 Installation Type 1

Installation Type 2

- Construct the pipe bed following the guidelines of section 3.2 →. Backfill to a level of 60% of pipe diameter with the specified backfill material compacted to the required compaction level.
- Backfill from 60% of diameter to 300 mm over the pipe crown with specified backfill material compacted to the required compaction level.
- ! **Note:** Backfill Configuration Type 2 is not practical for small diameter pipes.
- ! **Note:** Backfill Configuration Type 2 is not suitable for heavy traffic loading situations.

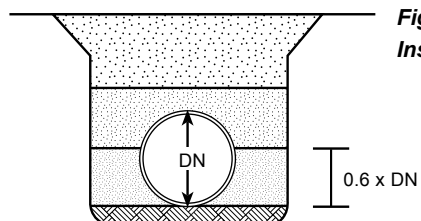

Figure 3–5 Installation Type 2

3.5 Backfilling Pipe

Immediate backfilling after joining is recommended as it will prevent two hazards, i.e. floating of pipe due to heavy rain and thermal movements due to large differences between day and night temperatures. Floating of pipe can damage the pipe and create unnecessary reinstatement costs. Thermal expansion and contraction can cause loss of seal due to movement of several pipe lengths accumulated at one joint.

If sections of pipe are placed into the trench and backfilling is delayed, each pipe should have the centre section backfilled to the crown to help minimize movements at the joint.

Proper selection, placement and compaction of pipe zone backfill are important for controlling the vertical deflection and are critical for pipe performance. Care must be taken so that the backfill material is not contaminated with debris or other foreign materials that could damage the pipe or cause loss of support. The haunching material in the area between the bedding and the underside of the pipe should be worked in and compacted before placing the remainder of the backfill (see Figure 3-6 and Figure 3-7).

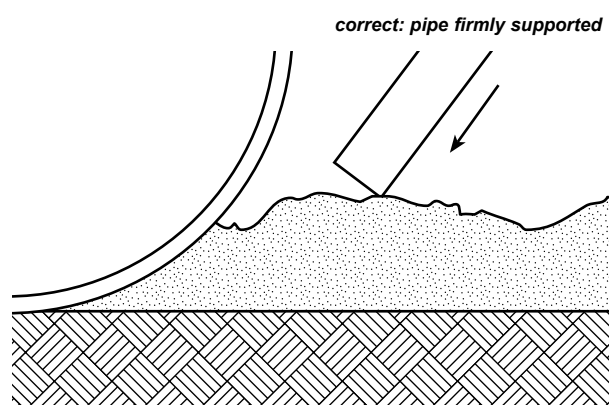

Figure 3-6 Proper haunch backfill

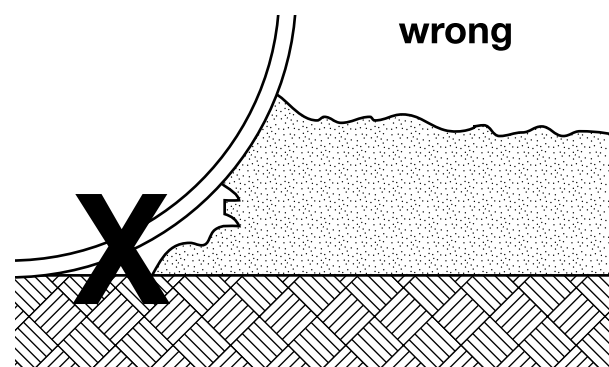

Figure 3-7 Improper haunch backfill

The depth of the layer being compacted must be controlled as well as the energy placed into the compaction method. Proper backfilling is typically done in 100 mm to 300 mm lifts depending on backfill material and compaction method. When gravel or crushed stone is used as backfill material, 300 mm lifts will generally be adequate since gravel is relatively easy to compact. Finer grained soils need more compaction effort and the lift height should be limited. Note that it is important to achieve proper compaction of each lift to ensure that the pipe will have adequate support.

Backfill Types SC1 and SC2 are relatively easy to use and very reliable as backfill materials for pipe. These soils have low moisture sensitivity. Backfill can be easily compacted using a plate vibrator compactor in 200 to 300 mm lifts. Occasionally, a filter fabric should be used in combination with gravel soils to preclude fines migration and subsequent loss of pipe support. See Appendix A for criteria.

Backfill Type SC3 soils are acceptable and are often readily available as backfill materials for pipe installations. Many local soils, in which the pipe is installed, are Type SC3 and therefore the excavated soil can be directly reused as pipe-zone backfill. Precaution is to be taken with these soils as they can be moisture sensitive. The characteristics of Type SC3 soil are often dictated by the characteristics of the fines. Moisture control may be required when compacting the soil to achieve the desired density with reasonable compaction energy and easily used compaction equipment. Compaction can be achieved by using impact compactor in 100 to 200 mm lifts.

Backfill type SC4 can only be used as pipe-zone backfill with the following precautions:

- Moisture content must be controlled during placement and compaction.
- Do not use in installations with unstable foundations or with standing water in the trench.
- Compaction techniques may require considerable energy, and practical limitations of relative compaction and resulting soil stiffness must be considered.
- When compacting, use lifts of 100 and 150 mm with an impact compactor such as Whacker or pneumatic rammer (pogo stick).
- Compaction tests should be conducted periodically to assure that proper compaction is achieved. See Appendix F for further information →.

The compaction of finer grain backfill is most easily accomplished when the material is at or near its optimum moisture content. When backfilling reaches pipe spring-line, all compaction should start near the trench sides and proceed towards the pipe.

Pipe zone backfill can be placed and compacted in such a way as to cause the pipe to ovalise slightly in the vertical direction. Initial vertical ovalisation, however, must not exceed 1.5% of pipe diameter as measured when backfill

reaches pipe crown. The amount of initial ovalisation obtained will be related to the energy required to achieve the relative compaction needed. The high energy levels that may be necessary with backfill Types SC3 and SC4 may lead to exceeding the limit. If this occurs consider a higher stiffness pipe or other backfill materials or both.

These recommendations are summarised in **Table 3-3**.

Backfill Soil Type	Hand-operated Impact Compactor	Hand-operated Vibrating Plate Compactor	Recommendations
Type SC1		300 mm	Two passes should provide good compaction
Type SC2		200 - 250 mm	Two to four passes, depending on height and required density
Type SC3	100 - 200 mm		Layer height and number of passes are dependent on required density Use at or near optimum moisture content. Check compaction.
Type SC4	100 - 150 mm		May require considerable compaction energy. Control moisture content to be at optimum. Verify compaction.

Table 3-3 Summary of recommendations for compaction of pipe-zone backfill

3.6 Compaction above Pipe

Type 1 installation requires the 300 mm over the pipe to be compacted. Trench backfill under areas subjected to traffic load is often compacted to minimize road surface settlement.

Table 3-4 shows the minimum cover height over the pipe necessary before certain compaction equipment may be used directly above the pipe. Care must be taken to avoid excessive compaction effort above the pipe crown which may cause bulges or flat areas. However, the material in this area must not be left loose and the desired specific density should be achieved.

Equipment Weight kg	Minimum Pipe Cover*(mm)	
	Tamped	Vibrated
< 50	-	-
50 - 100	250	150
100 - 200	350	200
200 - 500	450	300
500 - 1000	700	450
1000 - 2000	900	600
2000 - 4000	1200	800
4000 - 8000	1500	1000
8000 - 12000	1800	1200
12000 - 18000	2200	1500

*It may be necessary to begin with higher cover so that, as compaction is achieved, the cover will not be less than the minimum

Table 3-4 Minimum cover for compaction above pipe

3.7 Pipe Deflections

Deflection of the backfilled pipe is a good indicator of the quality of the installation. The expected initial vertical pipe deflection after backfilling to grade level is less than 2% for most installations.

A value exceeding this amount indicates that the desired quality of the installation has not been achieved and should be improved for the next pipes (i.e. increased pipe zone backfill compaction, coarser grained pipe zone backfill materials or wider trench, etc.).

Table 3-5 gives the maximum allowable initial deflection.

It is recommended to check the pipe deflection as soon as the pipe has been backfilled to grade level in order to get a continuous feedback on installation quality, see section 9.1 [→](#).

	Deflection % of Diameter
Large Diameter (DN ≥ 300) Initial	3.0
Small Diameter (DN ≤ 250) Initial	2.5

Table 3-5 Allowable initial vertical deflection

4 Joining Pipes

- 01
- 02
- 03
- 04**
- 05
- 06
- 07
- 08
- 09
- 10
- app.

FLOWTITE pipe sections are typically joined using FLOWTITE couplings. Pipe and couplings may be supplied separately or the pipe may be supplied with a coupling installed on one end. If the couplings are not delivered pre-mounted, it is recommended that they be mounted at the storage yard or at the trench side before the pipe is lowered to the trench bed.

The couplings may be supplied with or without a rubber centre stop register. If a centre register is not supplied a home-line will be marked on the pipe as an aid for jointing. Other joining system such as flanges, mechanical couplings and lay-up joints may also be used for joining FLOWTITE pipes.

4.1 FLOWTITE double Bell Couplings

Flowtite Pressure Coupling (FC)

The following steps (1-5) are meant for Flowtite Pressure Couplings.

Step 1 Foundation and Bedding

The bed must be over-excavated at each joint location to ensure that the pipe will have continuous support and does not rest on the couplings. The coupling area must be properly bedded and backfilled after the joint assembly is completed.

Step 2 Cleaning Coupling

Thoroughly clean double bell coupling grooves and rubber gasket rings to make sure no dirt or oil is present (Figure 4-1).

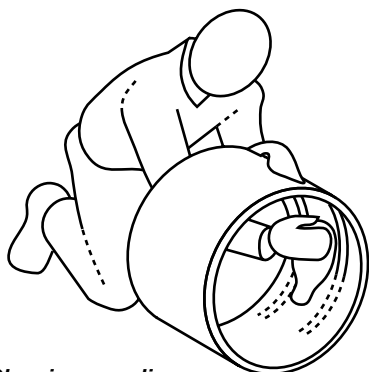

Figure 4-1 Cleaning coupling

Step 3 Install Gaskets

Insert the gasket into the groove leaving loops (typically two to four) of rubber extending out of the groove. Do not use any lubricant in the groove or on the gasket at this stage of assembly. Water may be used to moisten the gasket and groove to ease positioning and insertion of the gasket (Figure 4-2).

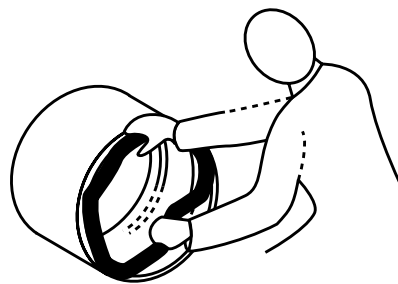

Figure 4-2 Installing gasket

With uniform pressure, push each loop of the rubber gasket into the gasket groove. When installed, pull carefully in the radial direction around the circumference to distribute compression of the gasket. Check also that both sides of the gasket protrude equally above the top of the groove around the whole circumference. Tapping with a rubber mallet will be helpful to accomplish the above.

Step 4 Lubricate Gaskets

Next, apply a thin layer of lubricant to the rubber gaskets (Figure 4-3). See Appendix I for normal amount of lubricant consumed per joint →.

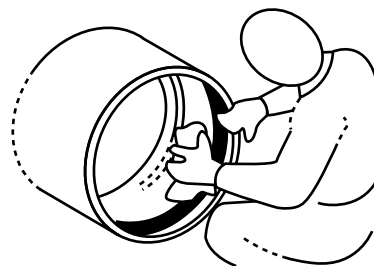

Figure 4-3 Lubricant gaskets

Step 5 Clean and Lubricate Spigots

Thoroughly clean pipe spigots to remove any dirt, grit, grease, etc. Inspect spigot sealing surface for possible damage. Apply a thin layer of lubricant to the spigots from the end of the pipe to the black alignment stripe. After lubricating, take care to keep the coupling and spigots clean (Figure 4-4). It has been found that placing a cloth or plastic sheet, approximately one metre square, under the jointing area will keep the spigot ends and gasket clean.

! Caution: It is very important to use only the correct lubricant. The supplier provides sufficient lubricant with each delivery of couplings. If for some reason you run out, please contact the supplier for additional supply or advice on alternative lubricants. Never use a petroleum based lubricant.

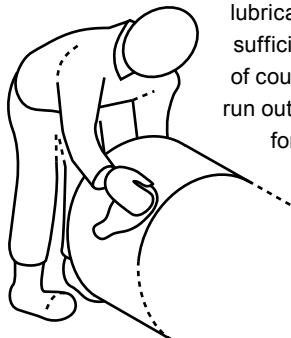

Figure 4-4 Cleaning spigot

Joining

If the coupling is not pre-mounted it should be mounted on the pipe in a clean, dry place before the pipes are joined. This is accomplished by placing a clamp or a sling around the pipe at a distance of 1 to 2 m from the spigot on to which the coupling will be mounted. Make sure the pipe spigot is resting at least 100 mm above the ground surface to keep away from dirt. Push the coupling on to the pipe spigot end manually and place a 100 x 50 mm timber across the coupling. Use two come-along jacks connected between the timber and the clamp and pull the coupling into position i.e. until the coupling is aligned with the "home line" or until the spigot touches the centre register (see Figure 4-5).

The following steps (6 to 8) apply to joining pipes using clamps or slings and "come-along jacks". Other techniques may also be used providing the general objectives outlined here are met. In particular, insertion of the spigot ends of the pipe should be limited to the home-line and any damage to the pipe and coupling avoided.

Step 6 Pipe Placement

The pipe with the coupling mounted is lowered onto the trench bed. In the location of the joint the trench should be over-excavated to ensure that the pipe will have a continuous support and does not rest on the couplings.

Step 7 Fixing of Clamps

Clamp (or sling) A is fixed anywhere on the first pipe or left in position from the previous joint. Fix Clamp (or sling) B on the pipe to be connected in a convenient position (Figure 4-6).

! **Note:** Clamp contact with the pipe shall be padded or otherwise protected to prevent damage to the pipe and to have high friction resistance with the pipe surface. If clamps are not available, nylon slings or rope may be used as in (Figure 4-7), but care must be taken in the alignment of the coupling.

Step 8 Join Coupling

Come-along jacks are placed one on each side of the pipe and connected to the clamps. The pipe is pulled into position into the coupling until it reaches the home-line or touches the centre register. Clamp A is then moved onto the next pipe to be joined.

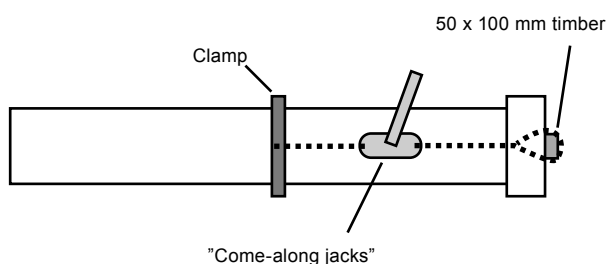

Figure 4-5 Mounting of coupling on pipe

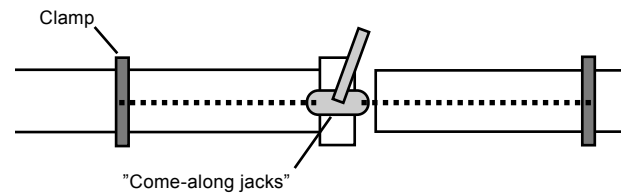

Figure 4-6 Pipe joining using clamps

The pipes can also be mounted by an excavator shovel or a crowbar (up to DN 300). The spigot ends are to be protected from any damage. The approximate mounting force can be calculated as follows:

Mounting forces in tons = (DN in mm / 1000) x 2

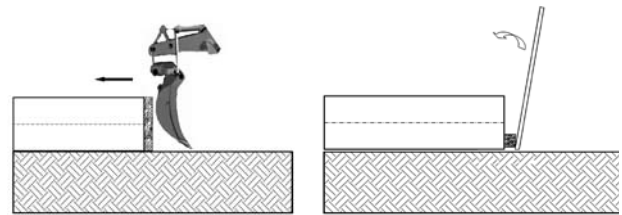

Figure 4-7 Mounting with excavator shovel or crowbar

Angular Deflection of FLOWTITE Couplings

Maximum angular deflection in service at each coupling taking into account combined vertical and horizontal, must not exceed the values given in Table 4-1. This can be utilized to accommodate gradual changes in line direction. The pipes should be then joined in straight alignment and thereafter deflected angularly as required. The maximum offset and corresponding radius of curvature are shown in Table 4-2 (See Figure 4-8 for definition of terms).

Nom. Pipe Diameter (mm)	Pressure (PN) in bars			
	Up to 16	20 Max. Angle of Deflection (deg)	25	32
DN ≤ 500	3.0	2.5	2.0	1.5
500 < DN ≤ 900	2.0	1.5	1.3	1.0
900 < DN ≤ 1800	1.0	0.8	0.5	0.5
DN > 1800	0.5	NA	NA	NA

Table 4-1 Angular Deflection at Double Coupling Joint

Angle of Deflection (deg)	Maximum Offset (mm) Pipe length			Radius of Curvature (m) Pipe length		
	3 m	6 m	12 m	3 m	6 m	12 m
3.0	157	314	628	57	115	229
2.5	136	261	523	69	137	275
2.0	105	209	419	86	172	344
1.5	78	157	313	114	228	456
1.3	65	120	240	132	265	529
1.0	52	105	209	172	344	688
0.8	39	78	156	215	430	860
0.5	26	52	104	344	688	1376

Table 4-2 Offset and Radius of Curvature

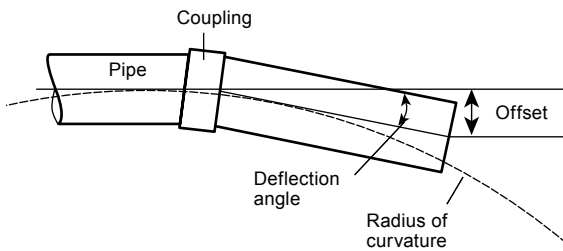

Figure 4-8 Flowtite coupling, angular joint deflection

! Note: The above is for information purposes. The minimum allowable length is a function of nominal pressure and backfill type and compaction, but in no case should it be less than 3 metres.

Angular deflected coupling joints are stabilised by the stiffness of the soil surrounding the pipe and coupling. Pressure pipes (PN>1) should have angularly rotated joints backfilled to minimum 90% standard proctor compaction. Coupling joints that are placed with vertical angular rotation, where the direction of the thrust is upward, should be backfilled to a minimum cover depth of 1.2 metres for operating pressures of 16 bar and greater.

Flowtite Sewer Coupling (FSC)

A gasket is used for the FSC, which is pre-equipped by the supplier and fixed to the coupling groove. With that the steps, described under 4.1 – cleaning of the grooves and installing of the gasket – can be dropped. All other working instructions and user data are identical with the steps – mentioned under 4.1 – for the Flowtite Pressure Coupling.

Pipe Misalignment

The maximum allowable misalignment of adjacent pipe ends is 5 mm (*see Figure 4-9*). It is recommended the misalignment be monitored near thrust blocks, valve chambers and similar structures, and at closure or repair locations.

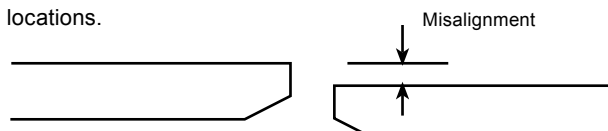

Figure 4-9 Misalignment

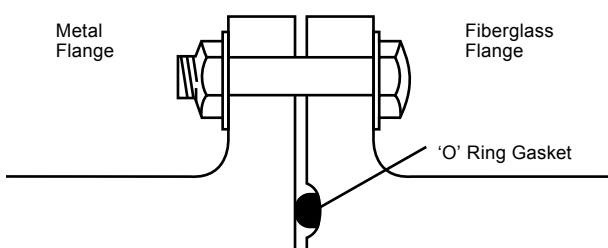

Figure 4-11 Flanged joint

4.2 Locked Joints (FBC)

The FLOWTITE locked joint is a double bell with rubber gaskets and locking rods to transfer axial thrust from one pipe section to another. On each side, the coupling bell has a standard rubber gasket and a rod-groove system, through which the load is transferred via compressive and shear action. The pipe spigot for locked joints has a matching groove.

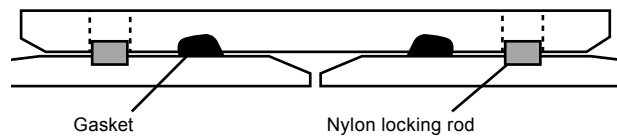

Figure 4-10 FLOWTITE locked joint

The joint is assembled by using a similar procedure as the standard FLOWTITE pressure coupling, except that there is no centre register. Steps 1 through 6 above should be followed. For step 7 the pipe is pulled in position until the groove in the pipe is visible through the opening in the coupling. The locking rod is then pushed into position with a hammer.

4.3 Flanged Joints

Contact Moulded

GRP flanges should be joined according to the following procedure: (*Figure 4-11*)

- 1** Thoroughly clean the flange face and the O-ring groove.
- 2** Ensure the sealing gasket is clean and undamaged.
- 3** Position sealing gasket in groove.
- 4** Align flanges to be joined.
- 5** Insert bolts, washers and nuts. All hardware must be clean and lubricated to avoid incorrect tightening. Washers must be used on all GRP flanges.
- 6** Using a torque wrench, tighten all bolts to 35 Nm torque, [20 Nm for small diameter DN 250] following standard flange bolt tightening sequences.
- 7** Repeat this procedure, raising the bolt torque to 70 Nm, [35 Nm for small diameter] or until the flanges touch at their inside edges. Do not exceed this torque. To do so may cause permanent damage to GRP flanges.
- 8** Check bolt torques one hour later and adjust if necessary to 70 Nm (35 Nm for small diameter).

Loose Ring Flanges

FLOWTITE pipe can also be supplied with loose ring (van Stone) flanges. The loose ring can be rotated to easily align with the bolt holes in the mating flange.

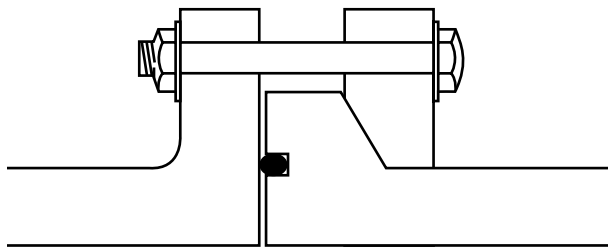

Figure 4-12 Loose ring flange with O-ring gasket

The loose ring flange can be manufactured for two types of gasket sealing using

- 1 an "O"-ring seal (groove required in flange face, see **Figure 4-12**) and
- 2 an "O"-ring profile gasket with steel ring for flat flange surfaces (no groove required) as shown in **Figure 4-13**.

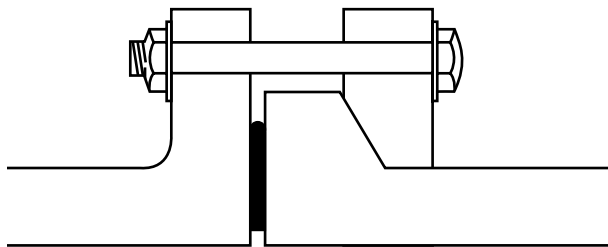

Figure 4-13 Loose ring flange with O-ring profile gasket with steel ring

The joining procedure for both types of loose ring flanges is identical and is described below.

- 1 Thoroughly clean the flange face to be joined and where applicable the "O"-ring groove.
- 2 Ensure the gasket to be used is clean and undamaged. Do not use defective gaskets.
- 3 Position the gasket onto the flange face. For the "O" ring seal, ensure that the gasket is pushed firmly into the "O"-ring groove. It is recommended that the "O"-ring be secured with small strips of tape or adhesive.

- 4 Align flanges to be joined.
- 5 Insert bolts, washers and nuts. All hardware must be clean and lubricated to avoid incorrect tightening. It is important that the mating surface between the bolt head/washers and backing ring plate are well lubricated to avoid excessive torque build up.
- 6 Use a torque wrench to tighten all bolts to the required torque settings in **Table 4-3** following standard flange bolt tightening sequences.
- 7 Check bolt torques one hour later and adjust if necessary to the set bolt torque.

Type of Gasket	PN	Maximum torque Nm*)
"O"-ring	6	50 x Pipe OD (in m)
"O"-ring	10	100 x Pipe OD (in m)
"O"-ring	16, 20	200 x Pipe OD (in m)
"O"-ring	25	125 x Pipe OD (in m)
"O"-profile with integral ring	6	45 x Pipe OD (in m)
"O"-profile with integral ring	10	75 x Pipe OD (in m)
"O"-profile with integral ring	16, 20	90 x Pipe OD (in m)
"O"-profile with integral ring	25	135 x Pipe OD (in m)

*) Based on standard flange dimensions according to ISO 7005

Table 4-3 Torque settings for loose ring flanges

- !** **Note:** When connecting two GRP flanges made with an "O"-ring gasket, only one flange shall have a gasket groove in the face.

4.4 Layup Joint

This type of joint is made from glass fibre reinforcements impregnated with polyester resin. It requires special designs, clean, controlled conditions and skilled, trained personnel. Special instructions will be provided when this type of joint is required (see **Figure 4-14**).

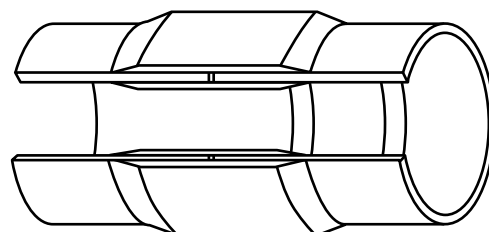

Figure 4-14 Lay-up joint

4.5 Other Joining Methods

Flexible Steel Couplings

(Straub, Tee-Kay, Arpol, etc. – see **Figure 4–15**)

When connecting FLOWTITE pipe to other pipe materials with different outside diametres, flexible steel couplings are one of the preferred jointing methods. These couplings consist of a steel mantle with an interior rubber sealing sleeve. They may also be used to join FLOWTITE pipe sections together, for example in a repair or for closure.

Three grades are commonly available:

- 1 Coated steel mantle
- 2 Stainless steel mantle
- 3 Hot dip galvanized steel mantle

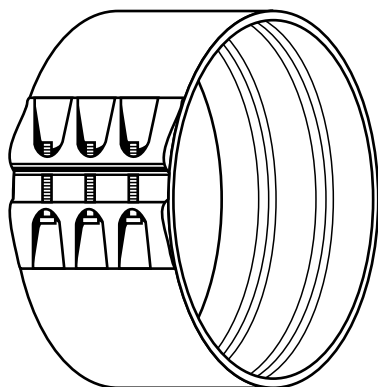

Figure 4–15 Flexible steel coupling

Control of the bolting torque of flexible steel couplings is important. Do not over torque as this may over stress the bolts or the pipe. Follow the coupling manufacturer's recommended assembly instructions, but with the pipe supplier's recommended bolt torque limits.

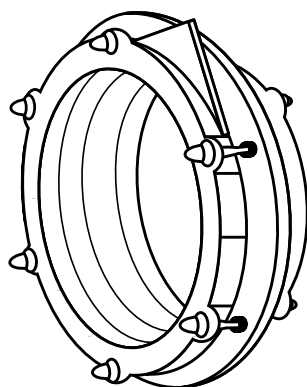

Figure 4–16 Dual bolt mechanical coupling

Mechanical Steel Couplings

(Viking Johnson, Helden, Kamflex, etc. see **Figure 4–16**)

Mechanical couplings have been used successfully to join pipes of different materials and diametres, and to adapt to flange outlets. There is a wide variation in the design of these couplings, including bolt size, number of bolts and gasket design. Large variations also exist in the diameter tolerance of other materials, which often results in higher bolt torque than necessary in order to achieve a tight seal on the FLOWTITE side.

Consequently, we cannot recommend the general use of mechanical couplings with FLOWTITE pipe. If a mechanical coupling is used to join FLOWTITE to another pipe material then only mechanical couplings with a dual independent bolting system should be used (**Figure 4–16**). This allows for the independent tightening of the FLOWTITE side, which typically requires less torque than recommended by the coupling manufacturer.

It is advised that the local FLOWTITE pipe supplier be consulted when mechanical couplings are contemplated for use on a project. Be prepared to present information on the specific design (brand and model). The pipe supplier can then advise under what conditions, if any, this design might be suitable for use with FLOWTITE.

Corrosion Protection

Regardless of the corrosion protection applied to the steel mantle, the balance of the coupling needs to be corrosion protected as well. Typically this involves the application of a shrink fit polyethylene sleeve over the installed coupling.

GRP Adapters

The FLOWTITE coupling can be used to join FLOWTITE pipe to other materials with the same outside diameter (**Table 6–1**) for non-pressure applications. For higher pressures consult the manufacturer.

Special GRP adaptors or stepped couplings can be made to connect GRP pipe with other materials or different diametres. Consult the manufacturer.

5 Thrust Restraints, Concrete Encasement and Connections to Rigid Structures

When the pipeline is pressurized, unbalanced thrust forces occur at bends, reducers, tees, wyes, bulkheads and other changes in line direction. These forces must be restrained in some manner to prevent joint separation. Usually this is most economically accomplished by use of thrust blocks or alternatively by direct bearing and friction between pipe and soil.

Direct transfer of thrust through friction and bearing are accomplished by using restraint joints and special pipes that transfer axial thrust. The accompanying fittings is designed for direct bury. A friction factor of 0.5 between Flowtite pipe and cohesionless soils may be considered when determining the required anchor length of the pipe connecting to the fittings.

Determination of need and design, as well as the level of steel reinforcement of concrete structures, is the responsibility of the owner's engineer. Flowtite fittings are designed to withstand the full internal pressure, while the concrete structure shall support its shape and transfer the load. As the expansion of the pressurized fittings is typically greater than the tensile strength of the concrete would carry, steel reinforcement to control crack widths should be considered. The following conditions also apply:

Thrust Blocks

Thrust blocks must limit the displacement of the fitting relative to the adjacent pipe to preserve the leak tightness of the Flowtite coupling joint. The resulting angular deflection shall be less than the values indicated in **Table 4-1**. For more details of pipe installation and system layout see clauses 5.1 and 5.2 [↗](#).

For operating pressures above 10 bar (PN>10) the block must completely surround the fitting. For lower pressures special fittings can be supplied that allow for partial embedding. The block should be placed either against undisturbed earth or backfilled with pipe zone materials selected and compacted as appropriate to meet the original native soil's strength and stiffness.

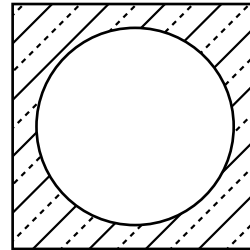

Section A-A

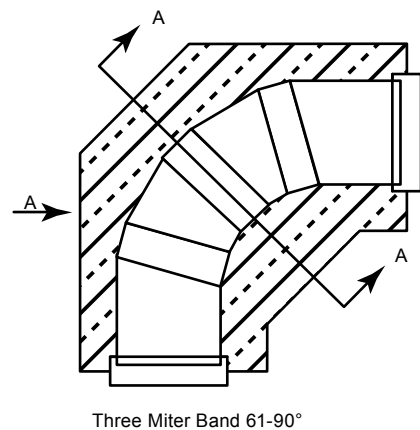
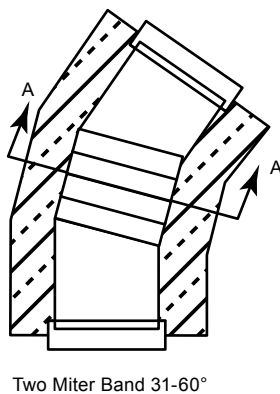
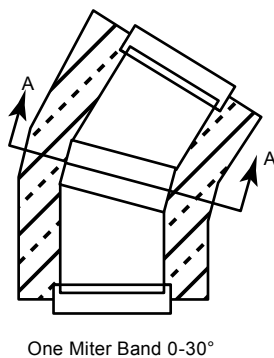
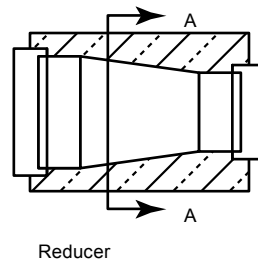
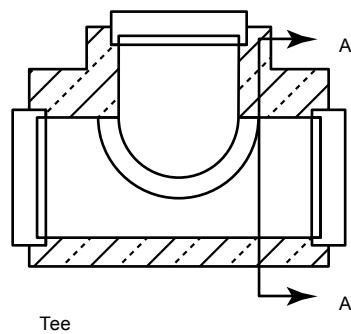

Figure 5-1 Thrust blocks

Thrust blocks are required for the following fittings when the line pressure exceeds 1 bar (100 kPa):

- 1 All bends, reducers, bulkheads and blind flanges.
- 2 Tees, when the branch pipe is concentric to the header pipe centreline.

Concentric manways (blind flange tees), drains and air vents, which do not generate unbalanced thrust in operation, do not require encasement, but do require thrust resistant branches and fittings.

! **Note:** The thrust block shapes shown are typical for illustration. The exact shape will be dependent on design and project requirement.

Valves

Valves must be sufficiently anchored to absorb the pressure thrust. More details on valves and chambers are provided in section 8.

Nozzles

Nozzles are tee branches meeting all of the following criteria:

- 1 Nozzle diameter \leq 300mm.
- 2 Header diameter \geq 3 times nozzle diameter.

! **Note:** it is not necessary to encase nozzle connections in concrete.

5.1 Concrete Encasement

When pipes (or fittings) must be encased in concrete, such as for thrust blocks, stress blocks, or to carry unusual loads, specific additions to the installation procedures must be observed.

DN	Maximum Spacing (m)
< 200	1.5
200 – 400	2.5
500 – 600	4.0
700 – 900	5.0
\geq 1000	6.0

Table 5–2 Maximum Strap Spacing

Pipe Anchoring

During the pouring of the concrete, the empty pipe or fitting will experience large uplift (flotation) forces. The pipe must be restrained against movement that could be caused by these loads. This is normally accomplished by strapping over the pipe to a base slab or other anchor(s). Straps should be a flat material of minimum 25 mm width, strong enough to withstand flotation uplift forces, with a minimum of two straps per section length and with the maximum spacing between straps as shown in **Table 5–2**. The straps should be tightened to prevent pipe uplift, but not so tight that additional pipe deflection is caused (see **Figure 5–2** →).

Pipe Support

The pipe should be supported in such a way that the concrete can easily flow completely around and fully underneath the pipe. Also, the supports should result in an acceptable pipe shape (less than 3% deflection and no bulges or flat areas).

Concrete Pouring

The concrete must be placed in stages allowing sufficient time between layers for the cement to set and no longer exert buoyant forces. The maximum lift heights, as a function of stiffness class, are as shown in **Table 5–3**.

Maximum lift is the maximum depth of concrete that can be poured at one time for a given nominal stiffness class.

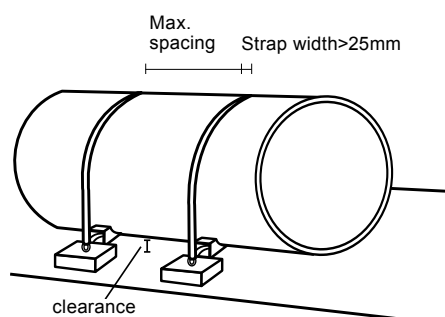

Figure 5–2 Pipe anchoring – Maximum spacing of straps see table Table 5–2

SN	Maximum lift
2500	Larger of 0.3 m or DN/4
5000	Larger of 0.45 m or DN/3
10000	Larger of 0.6 m or DN/2

Table 5–3 Maximum Concrete Pour Lifts

5.2 Connections to Rigid Structures

Excessive bending and shear stresses can develop in a pipe that moves excessively in relation to a rigid structure. Situations where this may occur are when a pipe passes through a wall (e.g. valve chamber or manhole), is encased in concrete (e.g. thrust block), or is flanged to a pump, valve or other structure.

For all connections to rigid structures action must be taken by the installer to minimize the development of high discontinuity stresses in the pipe. Angular deflection and misalignment at joints close to thrust blocks shall be avoided during installation.

Two options are available. The standard (preferred) uses a coupling joint cast into the concrete-pipe interface. The alternate wraps the pipe in rubber to ease the transition.

Standard

Where possible, cast a coupling joint in the concrete at the interface (**Figure 5-4**) so that the first pipe outside the concrete has complete freedom of movement (within the limits of the joint). For PN larger than 16 this standard method should be used, and the length of the short section pipe kept at the maximum indicated in **Figure 5-5**.

! **Caution:** When casting a coupling in concrete be sure to maintain its roundness so later joint assembly may be accomplished easily. Alternatively, make up the joint prior to pouring the concrete.

! **Caution:** Since the coupling cast in concrete is rigid, it is very important to minimize the vertical deflection and deformation of the adjacent pipe.

Alternate

Where the standard method is not possible, wrap (**Figure 5-4**) a band (or bands) of rubber (**Figure 5-5** and **Table 5-4**) around the pipe prior to placement of any concrete such that the rubber slightly protrudes (25 mm) from the concrete. Lay out the pipeline so the first completely exposed coupling joint is located as shown in **Figure 5-4**. For PN larger than 16 this alternate method is not recommended.

Construction Guidelines

- 1 When the design of the concrete structure is considered, it should be noted that any excessive settlement of the structure relative to the pipe can be the cause of a pipe failure.
- 2 It has been found that including a short length (rocker pipe) near the rigid connection is a good way to accommodate differential settlement (see **Figure 5-3** and **Figure 5-4**). The minimum length of the short length should be the larger of one DN or 1 metre, and the maximum length the larger of two DN or 2 metres. For small diameter pipe (DN < 300 mm) the length of the short piece is 300 mm to 500 mm. This rocker pipe section is used to account for some differential settlements that may occur. The rocker pipe should have straight alignment with the concrete structure at the time of installation to provide maximum flexibility for subsequent movements. Multiple short lengths or rocker pipes should not be used, as the short spacing between couplings may result in an unstable condition. Misalignment problems should be remedied by re-bedding the full pipe sections leading to the rocker pipe.

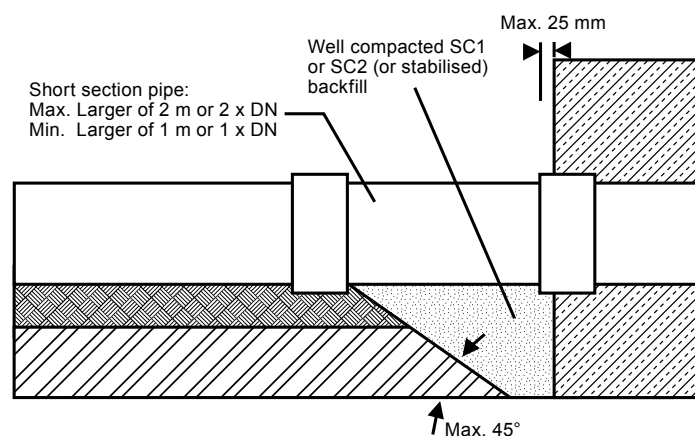

Figure 5-3 Standard connection – Coupling cast in concrete

Diameter	SN 2500 Pressure, bar					SN 5000 and larger
	1-3	6	9-10	12	15-16	All pressures
100 - 250	-	-	-	-	-	A
300 - 700	A	A	A	A	A	A
800 - 900	C	C	C	C	C	A
1000 - 1200	C	C	C	C	C	C
1300 - 1400	C	C	C	C	-	C
1500 - 1600	C	C	C	-	-	C
1800 - 2000	C	C	-	-	-	C
2200 - 2400	C	-	-	-	-	C

Table 5-4 Configuration of rubber wraps

3 Care must be taken to replace and properly compact backfill adjacent to the concrete structure. Construction of the concrete structure will frequently require over-excavation for formwork, etc. This extra excavated material must be restored to a density level compatible with surroundings to prevent excess deformation, or joint rotation adjacent to the structure. Type SC1 or SC2 backfill compacted to 90% Standard Proctor Density should be brought up to 60% of the pipe's diameter at the interface with the rigid structure (see **Figure 5-3** and **Figure 5-4**) and gradually tapered back. Stabilised backfill (cement) may also be used for this purpose.

Type A:

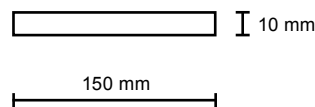

Type C:

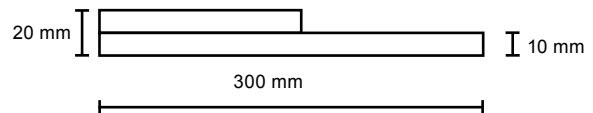

Rubber Wrap Placement

- 1** Position as shown in **Figures 5-4** and **5-5**.
- 2** Tape all seams and edges to assure no cement can get between the rubber and the pipe or between the rubber wraps.

Figure 5-5 Rubber wrap configuration – Rubber shall be 50 Durometer

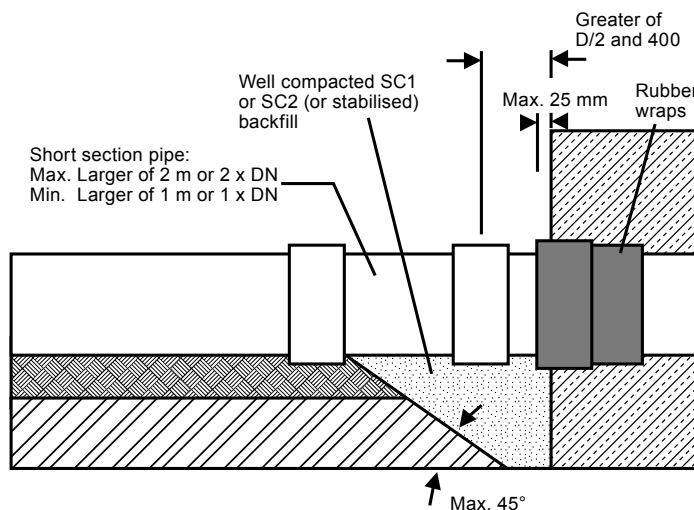

Figure 5-4 Alternate connection – Rubber wrap encased in concrete

5.3 Casings (Tunnels)

When Flowtite standard pipe (unequal exterior flush) is installed in a casing the following precautions should be observed.

- 1** Pipes may be placed into the casing by pulling (drawing) or pushing (jacking). Please consult the supplier for the calculation of the maximum insertion length/-force.
- 2** For an easy insertion and for protection from sliding damage the pipes should be equipped with plastic spacers, steel sleeves or wooden skids (as shown in **Figure 5-6 and 5-7**). These must provide sufficient height to permit clearance between the coupling joints and the casing wall.
- 3** Installation into the casing is made considerably easier by using lubricant between the skids and the casing wall. Do not use a petroleum based lubricant as it may cause harm to some gaskets.
- 4** The annular space between the casing and pipe may be filled with sand, gravel or cement grout. Care must be taken to not overstress or collapse the pipe during this step, particularly when grouting. Maximum grouting pressure is given in **Table 5-5**.

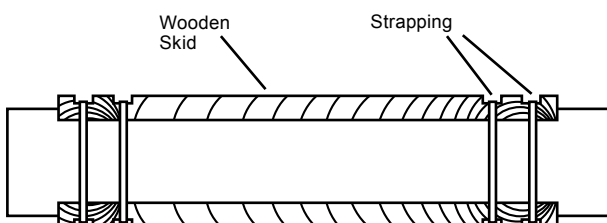

Figure 5-6 Typical skid arrangement

! **Note:** Do not wedge or brace the pipe in a manner that causes concentrated or point loads on the pipe. Consult the supplier prior to this step for advice on suitability of the chosen method.

! **Note:** If the annular space is not grouted and the pipe will be subjected to negative pressure, the pipe stiffness – installation combination must be sufficient to withstand the load. Consult the supplier for advice.

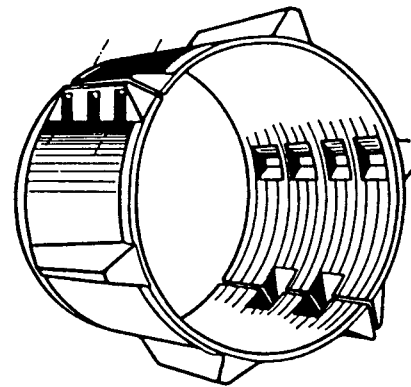

Figure 5-7 Plastic spacer unit

SN	Maximum Grout Pressure (bar)
2500	0.35
5000	0.70
10000	1.35

Table 5-5 Maximum Grouting Pressure (Pipe Invert) without Internal Supports

At the same time pipe systems with flush joint can be used.

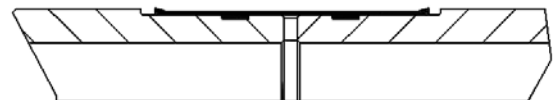

Figure 5-8 Flush joint

5.4 Concrete-wall Connections

When a pipe must pass through a concrete wall special precautions need to be followed to ensure continuous leak tightness of the system.

The connection systems are divided into two categories:

- 1** Made in situ
- 2** Precast

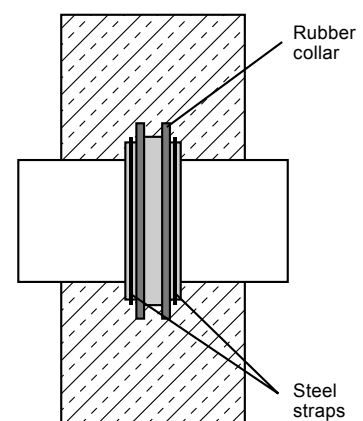

Figure 5-9 Rubber collar

Made in situ

An in situ connection is created when the concrete is poured directly at the site. Sometimes the pipe is completely encapsulated in the concrete base with the crown (top) of the pipe later cut away. No connection is needed in this case. At other times, only the ends of the pipe are inserted in the formwork limiting the concrete's contact to the pipe ends. For either case the market has developed rubber collars that are affixed to the pipe ends before the concrete is poured.

The rubber collar is first attached to the pipe using stainless steel straps. The collar is then embedded in the concrete. Due to its shape, a watertight seal between the concrete and pipe is achieved (*Figure 5–9*).

! Note: The water stop collar is not to be considered a load bearing anchor, or what is commonly called a puddle flange.

The recommended installation instructions for this collar are as follows:

- 1** Mark the end of the FLOWTITE pipe with the location of where the rubber collar will be located, and the extent of the concrete outer wall. The collar should be at the mid-point of the finished concrete wall.
- 2** Clean the entire outer surface of the pipe that will be in contact with the concrete, especially under the area where the collar is to be located. Any deep gouges should be ground smooth ensuring a better seal for the rubber collar.
- 3** Slip the rubber collar over the pipe end. Be careful to locate the collar at the expected mid-point of the concrete wall.
- 4** Install the stainless steel straps to press and fix the collar. To improve the sealing further it is generally recommended to use a fine concrete (i.e. no large aggregates) directly in contact with the collar. These collars can be used either with the pipe or with the Flowtite coupling. If one wants to achieve a flexible connection, it is recommended to use the Flowtite coupling and assemble the collar directly over the Flowtite coupling.

Precast

Precast connections are made off-site and are installed after the concrete has set. The inlet and outlet holes need to be dimensioned by the precast fabricator to fit FLOWTITE pipe at the time of initial production. The issue now becomes creating a water tight seal between FLOWTITE's outer wall and the pre-dimensioned hole in the concrete wall.

Manufacturers produce a special gasket which is designed for connections of a pipe passing through a concrete wall. The product is available for the complete diameter range of FLOWTITE pipe. The gasket is installed in the concrete hole as shown in *Figure 5–10*.

The hole through the wall can be created in two ways:

- 1** Using a diamond tipped hole-cutter – only practical for small diameters.
- 2** Using a cylindrical form, with the requisite outside diameter, during fabrication of the hole.

The gasket is kept in place by compression. Sealing is through compression/deformation of the lips.

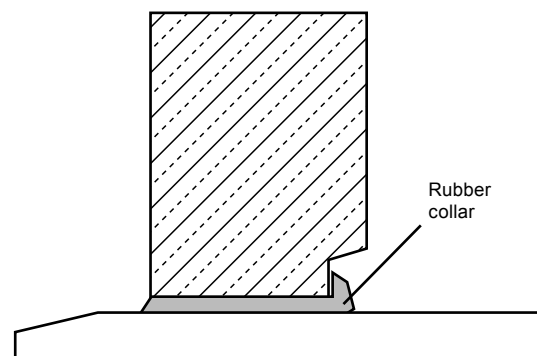

Figure 5–10 Rubber collar in concrete wall

6 Field Adjustments

6.1 Length Adjustment

A large majority of the pipe supplied by Flowtite producers has the outside diameter of the barrel of the pipe within the tolerance range of the calibrated spigot (**Table 6-1**). These pipes are often marked as Adjustment Pipe or similar. The following procedures will assist in correctly making the length adjustment:

- 1** Ensure that the pipe diameter is within the spigot tolerance range.
- 2** Determine the length required and mark a square cut on the selected pipe.
- 3** Cut the pipe at the appropriate location using a circular saw with a diamond coated blade. Use proper eye, ear and dust protection. Consult the pipe supplier for recommendations.
- 4** Clean the surface in the jointing area, sand smooth any rough spots and with a grinder bevel grind the pipe end to ease assembly (see **Figure 6-1**). No further grinding is necessary.

Dia-meter Series	DN (mm)	Minimum OD (mm)	Maximum OD (mm)	Spigot width (mm)	L (mm)
B2	100	115.5	116.0	110.0	3
B2	150	167.5	168.0	110.0	4
B2	200	220.0	220.5	110.0	4
B2	250	271.6	272.1	110.0	6
B2	300	323.4	324.5	130.0	6
B2	350	375.4	376.4	130.0	8
B2	400	426.3	427.3	130.0	10
B2	500	529.1	530.1	130.0	14
B1	600	616.0	617.0	160.0	17
B1	700	718.0	719.0	160.0	20
B1	800	820.0	821.0	160.0	20
B1	900	922.0	923.0	160.0	20
B1	1000	1024.0	1025.0	160.0	20
B1	1200	1228.0	1229.0	160.0	20
B1	1400	1432.0	1433.0	160.0	20
B1	1600	1636.0	1637.0	160.0	20
B1	1800	1840.0	1841.0	160.0	20
B1	2000	2044.0	2045.0	160.0	20
B1	2400	2452.0	2453.0	160.0	20
B1	2600	2656.0	2657.0	160.0	20
B1	2800	2860.0	2861.0	160.0	20
B1	3000	3064.0	3065.0	160.0	20

Table 6-1 Spigot Dimensions and Tolerances.

! **Note:** Series B2 matches with Ductile Iron spigot O.D. Series B1 is GRP O.D. series. In some countries the Ductile Iron (B2) series may not be used.

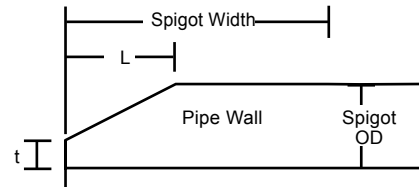

Figure 6-1 Pipe spigot and bevel dimensions definition for coupling joints

! **Note:** For field closure section, double the spigot width.

The design of the pipes does not require any sealing of the spigot ends after field cutting. If national law demands sealing, e.g. because of maintenance of industrial health and safety standards, one has to comply with it.

! **Note:** In relation to this it is of great importance that the interior edge of an adjustment pipe is chamfered after field cutting.

6.2 Field Closures with FLOWTITE Couplings

FLOWTITE couplings can be used for field closures and repairs. The minimum length of the closure pipe should be 1 metre. In addition, the closure pipe should not be adjacent to a “rocker” pipe, i.e., the short length meant to provide flexibility adjacent to rigid connections (see **Figure 5-4**).

Procedure

Measure the distance between the pipe ends where you want to set in the closure pipe. The closure pipe should be 10-20 mm shorter than the measured length. The narrower the gap the easier it will be to make the closure.

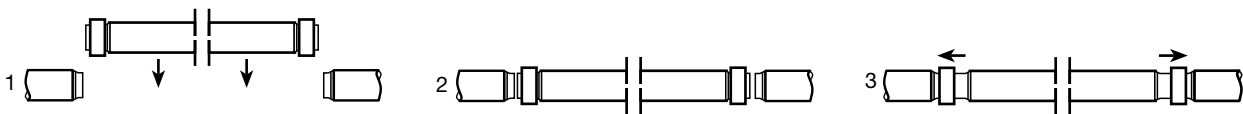

Figure 6-2 Closure section assembly

Pipe Selection

Choose a pipe which is within the spigot diameter tolerance. These pipes will have the required spigot outside dimension for joining along the entire pipe length. If possible choose a pipe with the outside dimension at the low end of the spigot range (see **Table 6-1**).

Pipe Preparation

Mark the pipe length required and make a cut perpendicular and square to the pipe axis with a circular saw. Use a grinding tool to make a 20 degree bevel on the pipe end and round-off the corners.

Be careful that the remaining thickness on the pipe spigot end is not less than one half the pipe thickness. It is also important to have a minimum chamfer length, L, for guiding the pipe end without damaging the gasket. Follow the recommended lengths in **Table 6-1**. After bevelling, use sandpaper to remove any sharp corners on the pipe surface which may have been caused by the cutting. Smooth the spigot of any rough spots.

! **Note:** The spigot width must be at least equal to the coupling width. This will be twice the values shown in **Table 6-1**.

Please make sure that the surface has no grooves, and that the spigot OD is within the limits shown in **Table 6-1**.

Installation

- 1** Select two couplings, remove the centre registers, and leave the gaskets in place. Clean the couplings if necessary. The gasket groove must be free of dirt to allow unrestricted deformation of the gasket.
- 2** Lubricate carefully, including between the lips.
- 3** Lubricate also the clean spigot ends of the closure pipes with a thin continuous layer of lubricant. Do not forget the bevelled surfaces.
- 4** Place one coupling square onto the end of the closure pipe so that the gasket is in contact around its entire circumference. Push or pull the coupling uniformly onto the closure pipe until the entire coupling is resting on the spigot end. It may be necessary to gently help the second ring over the chamfered end of the pipes. Repeat with the second coupling on the other end.

- 5** Mark home-lines onto the adjacent pipe spigot ends to control the uniform backward movement of the coupling. The home-line's location is calculated as follows:

$$HL = (Wc - Wg) / 2$$

HL – homeline

Wc – width of the coupling

Wg – width of gap between closure pipe and adjacent pipe (measured).

- 6** Set the closure pipe in the trench aligned with the adjacent pipes and with equal clearance on either side. Any angle or tilt will complicate the assembling process.
- 7** Clean the spigot ends of the adjacent pipes and lubricate with an even, thin layer. Install special tools to pull the coupling back to closing position. (consult your supplier for information about the tools). It is recommended that you pull the couplings over both sides simultaneously, keep the closure pipe centred and minimize pipe end contact. Stop pulling when the coupling's edge touches the home-line. For man-entry size pipes, an individual inside the pipe watching the assembly process can be advantageous.
- 8** The compaction of the backfill around a field closure pipe is very important and should be no less than 90% SPD. Often the closure area is over excavated for ease of access. This is recommended to prevent excessive movement and joint rotations.

! **Note:** After the coupling is in final position, a feeler gauge may be used to assure that gasket lips are properly oriented.

6.3 Field Closures with Non-FLOWTITE Couplings

Follow the general procedures of section 6.2 [→](#) except that the closure pipe will not typically need to have the special long machined spigot ends.

The installation procedures for the particular coupling used must be followed (see section 4.5 [→](#)).

7 Other Installation Procedures and Considerations

01
02
03
04
05
06
07
08
09
10
app.

7.1 Multiple Pipes in Same Trench

When two or more pipes are installed parallel in the same trench, clear spacing between the pipes should be as shown in **Figure 7-1**. Space between pipe and trench wall should be as shown in **Figure 3-1**.

It is advisable when laying pipes of different diameters in the same trench to lay them with the same invert elevation. When this is not possible, use backfill material type SC1 or SC2 to fill all the space from the trench bottom to the invert of the higher pipe. Proper compaction must be achieved (min. 90% SPD).

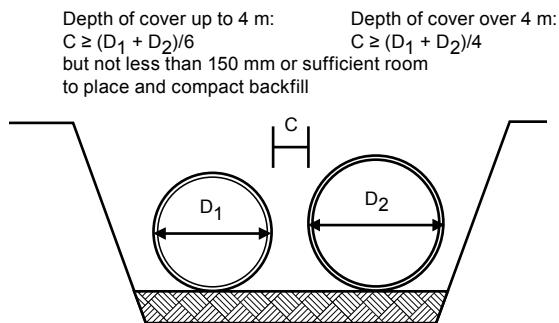

Figure 7-1 Spacing between pipes in the same trench

Depth of cover up to 4 m: $C \geq (D_1 + D_2)/6$
but not less than 150 mm or sufficient room to place and compact backfill

Depth of cover over 4 m: $C \geq (D_1 + D_2)/4$

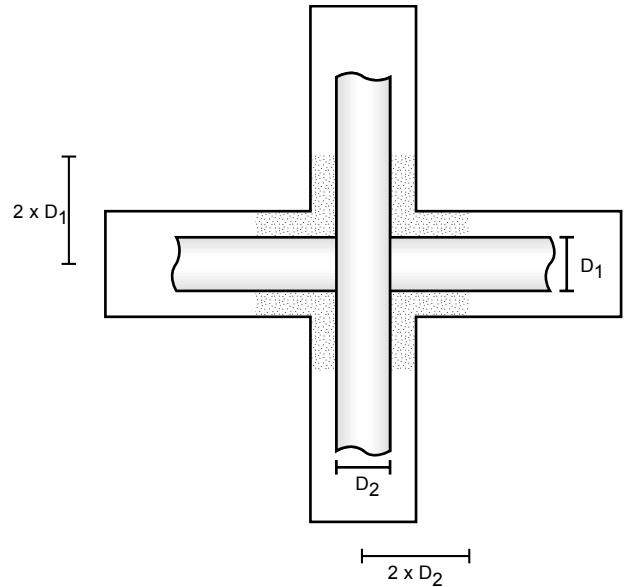

Figure 7-3 Top view of backfill in cross-over.

7.2 Cross-Overs

When two pipes cross, so that one passes over the other, vertical spacing between pipes and installation of the bottom pipe should be as shown in **Figure 7-2**.

In some cases, it is necessary to lay a pipe under an existing line. Extra care should be taken not to damage the existing pipe. It should be protected by fastening it to a steel beam crossing the trench. It is also advisable to wrap the pipe in order to protect it from impact damage. When the new pipe is laid, backfill material type SC1 or SC2 must be placed back into the trench and compacted to a minimum of 90% SPD completely around both pipes plus 300 mm above the crown of the upper pipe. This backfill should extend at least twice the diameter into each trench (see **Figure 7-3**).

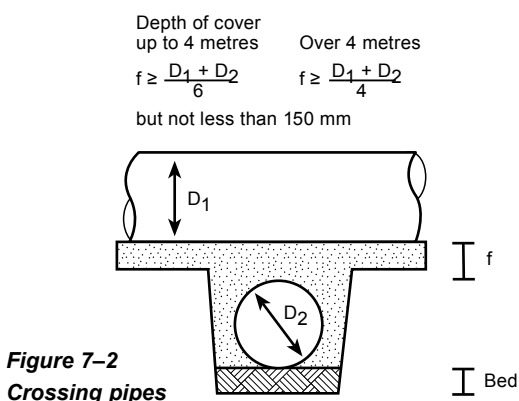

Figure 7-2 Crossing pipes

Depth of cover up to 4 metres: $f \geq \frac{D_1 + D_2}{6}$
but not less than 150 mm

Over 4 metres: $f \geq \frac{D_1 + D_2}{4}$

Use only Type A or Type B backfill materials compacted to a minimum of 90% Relative Compaction

7.3 Unstable Trench Bottom

Where the trench bottom has soft, loose or highly expansive soils, it is regarded as unstable. An unstable trench bottom must be stabilised before laying pipe or a foundation must be constructed to minimize differential settlement of the trench bottom. A well graded sandy gravel compacted to 90% SPD or crushed stone is recommended for use in foundation layers.

The depth of the sandy gravel or crushed stone material used for foundation depends upon the severity of the trench bottom soil conditions, but should not be less than 150 mm. The normal bedding must be placed on top of such foundations. When crushed rock is used the use of filter cloth to completely surround the foundation material will prevent foundation and bedding materials from migrating into one another which could cause loss of pipe bottom support. Filter cloth is not needed if the same material is used for foundation and bed, or if graded sandy gravel is used for the foundation. Additionally, the maximum pipe section length between flexible joints shall be 6 metres.

7.4 Flooded Trench

When the groundwater table is above the trench bottom, the water level must be lowered to at least the trench bottom (preferably about 200 mm below) prior to preparation of the bed. Different techniques may be used depending on the nature of the native material.

For sandy or silty soils, a system of well-points to a header pipe and a pump is recommended. The spacing between individual well-points and the depth at which they will be driven depends on the groundwater table and the permeability of the soil. It is important to use a filter around the suction point (coarse sand or gravel) to prevent clogging of the well-points by fine grained native material.

When the native material consists of clay or bedrock, well-points will not work. Dewatering is more difficult to achieve in this case. The use of sumps and pumps is recommended. If the water cannot be maintained below the top of the bedding, sub-drains must be provided. The sub-drains should be made using single size aggregate (20 - 25 mm) totally embedded in filter cloth. The depth of the sub-drain under the bed depends on the amount of water in the trench. If the groundwater can still not be maintained below the bed, filter cloth should be used to surround the bed (and if necessary the pipe zone area as well) to prevent it from being contaminated by the native material. Gravel or crushed stone should be used for bed and backfill. The following cautions should be noted when dewatering:

- Avoid pumping long distances through the backfill materials or native soils, which could cause loss of support to previously installed pipes due to removal of materials or migration of soil.
- Do not turn off the dewatering system until sufficient cover depth has been reached to prevent pipe flotation.

7.5 Use of Trench Supports

Care must be taken to ensure proper support between native soil and backfill when sheeting is removed. Removing the sheeting in steps and direct compaction of pipe-zone backfill against the trench wall provides the best support to the pipe and fills the voids that frequently occur behind sheet piling. If the sheeting is pulled after the pipe-zone backfill has been placed, the backfill loses support which reduces the support to the pipe, especially when voids form behind the sheeting. To minimize this loss of support the sheeting should be vibrated during removal.

Make sure that there are no voids or lack of backfill between the outside of the sheeting and the native soil up to at least

1 m above the pipe crown. Use only backfill type SC1 or SC2 between the temporary sheeting and the native soil, compacted to at least 90% SPD.

For permanent sheeting, use sheeting of sufficient length to properly distribute the pipes lateral loads at least 300 mm above the pipe crown. The quality of the permanent sheeting should be such that it lasts for the design life of the pipe.

Backfill procedures are the same as for standard installations. Permanent sheeting can be assumed to be a group 1 native soil.

7.6 Trench Construction in Rock

Minimum dimensions for pipe installations in a rock trench should be as in 3.1 →. Where the rock ends and the pipe passes into a soil trench area (or reverse), flexible joints should be used as shown in **Figure 7-4**.

Alternatively, use of cement stabilised backfill (see section 5.2) for the foundation and bedding of a pipe just passing through a rock-soil transition would negate the need to locate a flexible joint at this transition. Trench construction should be according to the method applicable for the native soil condition.

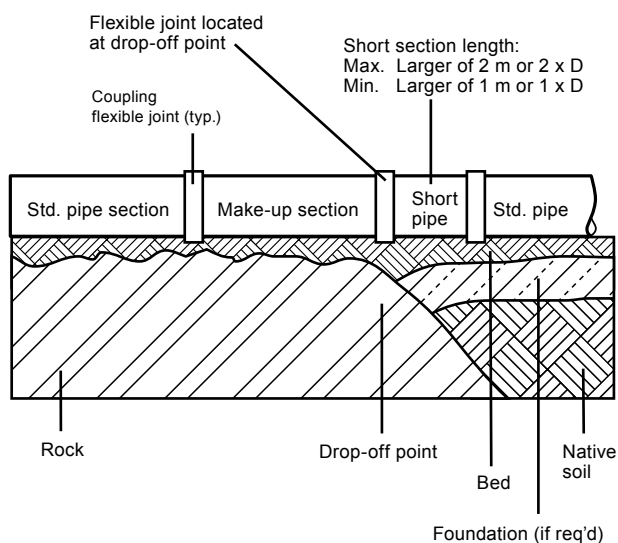

Figure 7-4 Method of trench construction and pipe layout at rock-soil trench transition or at abrupt changes in bedding conditions.

7.7 Inadvertent Over-Excavation

Any inadvertent over-excavation of the trench walls or the trench bottom in the foundation, bed or pipe zone areas should be filled with backfill material compacted to a least 90% relative compaction.

7.8 Installation of Pipes on Slopes (Parallel)

General

- The angle at which slopes can become unstable depends on the quality of the soil. The risk of unstable conditions increases dramatically with slope angle.
- In general, pipes should not be installed on slopes greater than 15 degrees, or in areas where slope instability is suspected, unless supporting conditions have been verified by a proper geotechnical investigation.

Aboveground Installation

- The preferred method of installing pipes on steep slopes is above ground as above ground structures such as pipe supports are more easily defined, the quality of installation is easier to monitor and settlement easier to detect.
- See above ground installation brochure for more information [→](#).

Buried Installation

Before pipes are installed underground on slopes greater than 15 degrees, it is recommended that a geotechnical engineer be consulted. Flowtite pipes may be installed on slopes greater than 15 degrees provided the following minimum conditions are achieved:

- Long-term stability of the installation can be ensured with a proper geo-technical design.
- For slopes over 15 degrees, use either SC1 or cement-stabilised backfill in the pipe zone as backfill material.
- For slopes greater than 15 degrees, use one anchor rib at the centre of each pipe section.
- Installation should always proceed from the low point and progress up the slope. Each pipe should be properly backfilled to grade before the next pipe is placed in the trench.

- The surface over the completed pipe trench must be protected against erosion from flowing water.
- Pipes are installed in straight alignment (plus or minus 0.2 degrees) with a minimum gap between pipe spigots.
- Absolute long-term movement of the backfill in the axial direction of the pipe must be less than 20 mm.
- The installation is properly drained to avoid washout of materials and ensure adequate soil shear strength.
- Stability of individual pipes is monitored throughout the construction phase and the first phases of operation. This can be done by controlling the gap between pipe spigots.
- A special pipe design may be required, consult the pipe supplier.

Perpendicular to the hillside

When pipes are installed perpendicular to the fall line of a steep slope, consultation with a geotechnical engineer is recommended when the slope angle exceeds 15 degrees to assure that the hillside remains stable.

The surface of the completed trench must be configured to eliminate depressions and preclude the formation of puddles water. The collection of water on a slope may reduce the stability of the slope.

8 Accommodating Valves and Chambers

- 01
- 02
- 03
- 04
- 05
- 06
- 07
- 08
- 09
- 10
- app.

Most pressure pipelines periodically have in-line valves for isolating a portion of the supply or distribution system, air and vacuum relief valves at high points in the pipeline to slowly release accumulated air thereby avoiding blockages or to allow air to enter in order to avoid under-pressure, and clean out (wash out) or drainage chambers. All of these different appurtenances can be accommodated with FLOWTITE pipe. The ultimate responsibility for the design of the piping systems is the professional engineer. However, over the years Flowtite Technology engineers have observed many different methods of incorporating these appurtenances into a pipeline using FLOWTITE pipe. This section is devoted to offering the design engineer or contractor some guidelines on accommodating valves and chambers in a pressure FLOWTITE pipeline.

8.1 Anchoring In-Line Valves

Flowtite pipe is designed to handle nominal axial loads, but is not designed to accommodate thrust and shear loads that may result from the inclusion of valves in the piping system. Loads from valves must be externally restrained as required by AWWA C600-93. Several methods for anchoring valves are described. The best method will be dependent on the specific operating conditions for each system. Generally, the best method is dependent on pipe diameter and operating pressure.

There are two basic considerations for in-line valves: are they directly accessible (installed in chambers) or not (direct buried)? Generally, smaller diameter valves are direct buried without the use of concrete chambers for easy access. Consequently, our guidelines are based on these two different situations.

Direct Bury

Type 1 The lowest cost and easiest installation for a small diameter valve is to direct bury it, encapsulated in its own concrete thrust block (See **Figure 8-1**). This method can be used with larger valves, the only limit being a reasonable thrust block design. The reinforced concrete thrust block must be properly designed to resist thrust from a closed valve with movement limited to the leaktightness of the joint.

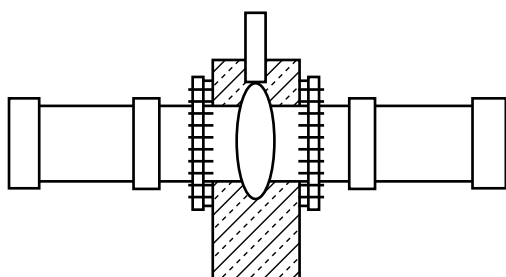

Figure 8-1 Type I – Valve encased in thrust block

The following guidelines should be observed in designing the Type 1 arrangement:

- 1** The size of the concrete thrust block is based on the local soil stiffness, backfill materials and installation conditions. Limit movement to 15 mm.
- 2** The flanged stubs should be no more than 500 mm in length, with a FLOWTITE coupling on the outside leg connecting the stub to a rocker pipe (**Figure 5-4** →).

Type 2 The anchoring method here is similar to Type I except that the valve body can be accessed (see **Figure 8-2**). While allowing a relatively simple installation, the valve may be available for servicing. The limit of use is dependent on the strength of the stub of steel or ductile iron pipe and the attached anchoring collar. For small thrust loads, only one side of the valve needs to be anchored.

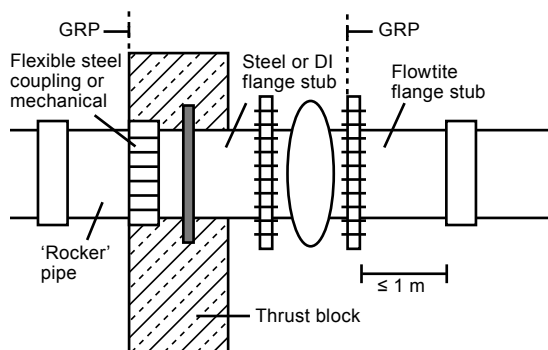

Figure 8-2 Type II – Thrust block adjacent to valve

The following guidelines should be observed in designing the Type II arrangement:

- 1** The size of the thrust block is based on the local soil stiffness, backfill material and installation conditions. Limit lateral movement to preserve the leaktightness of the joint.
- 2** The flanged stubs should be no more than 1 metre in length. The stub, with the flange or anchor collar, connects to the FLOWTITE rocker pipe with the standard FLOWTITE coupling.
- 3** If steel or ductile iron stubs are used, the use of flexible steel couplings or transitions (dual bolting) mechanical couplings is recommended.

Chambers

Type 3 This method can be used for all but the larger, higher pressure valves. The limit of use is dependent on the ability to place the structural support system into the valve chamber. The support system must be designed to accept the total axial thrust without over-stressing the valve flanges or the reinforced concrete valve chamber walls. The valve chamber acts as the thrust block and must be designed as such. The thrust restraint is placed on the compression side of the valve to transfer the thrust directly to the chamber wall. The other end of the pipe system is relatively free to move axially allowing for movement due to temperature change and Poisson effect.

The assumption inherent in **Figure 8-3** is that the thrust acts only in one direction. However, consideration must be given to the possibility of back pressure on a closed valve which could create a thrust load in the opposite direction. To accommodate this possibility the structural support system can be designed to handle load in either direction. The details are left up to the design engineer.

The following guidelines should be observed in designing the Type III arrangement:

- 1 Thrust and shear from the valve is to be supported through a steel frame support system. Standard FLOWTITE pipe and flanges can be supplied for this method of use.
- 2 The standard FLOWTITE pipe is to have either a rubber wrap or sealing gasket at the outward concrete wall penetration to reduce local stresses caused by the constraint of free radial displacement during pressurization.

- 3 The valve chamber must be designed to accept the full axial thrust and vertical weight of the valve. Local reinforcements of the valve chamber foundation and walls will be required to accept the axial forces at the attachment points.
- 4 The valve chamber is to be designed as a thrust block to resist axial thrust. The backfill selection, placement and compaction must be sufficient to resist settlement and lateral forces created by the valve closure. Limit lateral movement to preserve the leaktightness of the joint.
- 5 There must be a rocker pipe placed outside the valve chamber according to standard installation practices.
- 6 The thrust is taken via compression of the structural support system. No axial load is transmitted to the pipe.
- 7 Use cement stabilised backfill, or gravel compacted to 90% relative compaction, to fill the void beneath the pipe exiting the valve chamber structure (see **Figure 5-3** →).

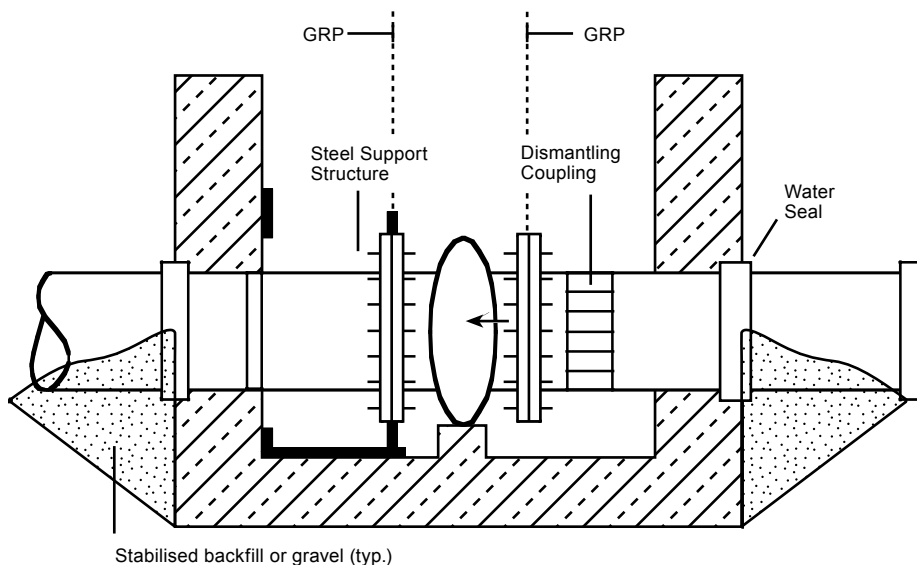

Figure 8-3 Type III – Use of structural support system to accommodate thrust forces

Type 4 This method (**Figure 8-4**) can be used for anchoring any valve with pressures up to 16 bar. The limitation in use of this method are the practical limits of FLOWTITE pipe reinforcement and puddle flange length. The puddle flange is placed on the compression side of the valve directly loading the chamber wall which acts as a thrust block. The other side of the pipe system in the chamber is relatively free to move axially to allow movement due to temperature change and Poisson effect. The following guidelines should be observed in designing the Type IV arrangement:

- 1** A "special" pipe will have a GRP puddle flange fabricated on the compression-side which is embedded into the valve chamber wall acting as an anchor.
- 2** The other pipe leg is free to move axially through a sealing gasket in the valve chamber wall.
- 3** The weight of the valve is to be supported from the base of the valve chamber, and the valve chamber must be designed to accept the full axial thrust of the valve. A concentration of reinforcement bars will be required to accept the axial forces from the embedded puddle flange.

- 4** The valve chamber is to be designed as a thrust block to resist axial thrust. The backfill selection, placement and compaction must be sufficient to resist settlement and lateral forces created by the valve closure. Lateral movement limited to 15 mm.
- 5** The "special" pipe will incorporate a coupling embedded in the valve chamber wall. The "special" pipe within the valve chamber will be reinforced to accept the axial loads and local stresses at the interior face of the concrete chamber. Please advise the Flowtite supplier of maximum anticipated thrust loads so that the proper reinforcement for the "special" pipe can be designed.
- 6** There must be a rocker pipe placed outside the valve chamber according to standard installation practices (see **Figure 5-4** →).
- 7** Use cement stabilised backfill, or gravel compacted to 90% relative compaction, to fill the voids under the pipe outside the valve chamber structure (see **Figure 5-3** →).

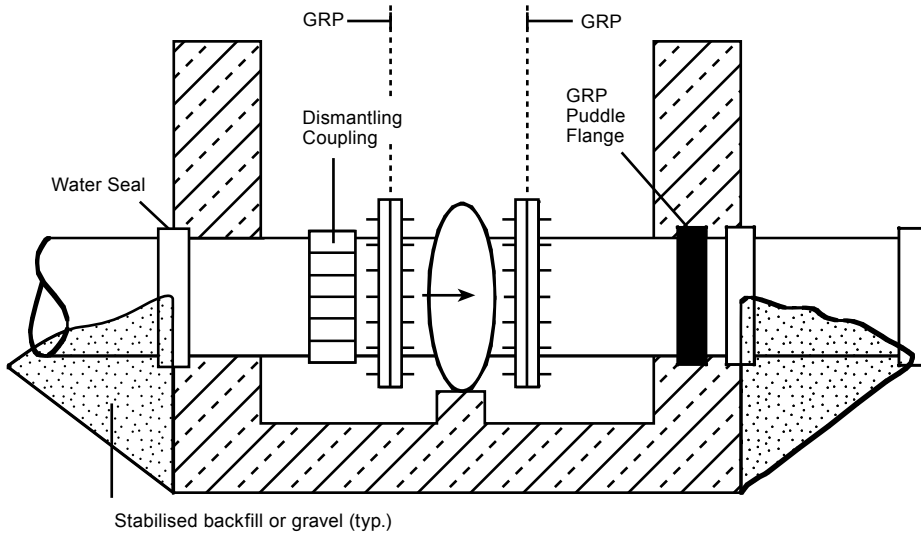

Figure 8-4 Type IV – Use of puddle flange to accommodate thrust forces

Type 5 This anchoring method (*Figure 8–5*) may be used for any application. The only limitation in use would be the size of the valve chamber. The valve chamber is to be designed as the thrust block. When the dimensions of the thrust block face required are larger than the physical dimensions of the valve chamber, extend the dimensions of the down-stream side of the valve chamber to meet the thrust block requirements. The thrust restraint flange is placed on the compression side of the valve to transfer the thrust directly to the chamber wall, which acts as a thrust block. The other end of the pipe system is relatively free to move axially to allow movement due to temperature change and Poisson effect.

The following guidelines should be observed in designing the Type V arrangement:

- 1 The weight of the valve is to be supported from the base of the valve chamber. The thrust from a closed valve is to be taken by a steel pipe stub anchored into the valve chamber wall by a welded flange on the compression side of the valve.
- 2 A flexible steel coupling or a transition mechanical coupling is to provide transition between the steel pipe stub and a standard FLOWTITE rocker pipe outside the valve chamber.
- 3 The other pipe leg is free to move axially through a sealing gasket in the valve. A concentration of reinforcement bars will be required to accept the axial forces from the embedded puddle flange.
- 4 The valve chamber is to be designed as a thrust block to resist axial thrust. The backfill selection, placement and compaction must be sufficient to resist settlement and lateral forces created by a valve closure. Lateral movement limited to 15 mm.

5 There must be a rocker pipe placed outside the valve chamber according to standard installation practices (see *section 5.2* →).

6 Use cement stabilised backfill, or gravel compacted to 90% relative compaction, to fill the void beneath the pipes exiting the valve chamber structure (see *Figure 5–3* →).

8.2 Air and Vacuum Valves

It is common practice to locate air or combination air/vacuum relief valves at high points in a long transmission line. The valves should be designed to slowly release any accumulated air in the high point of a line, which might limit a block flow. Likewise, vacuum relief valves limit the amount of negative pressure a pipeline might experience by opening when under-pressure is sensed by the valve. The detail design and sizing of these valves is beyond the scope of this installation guide. However, guidelines are offered here on the general layout of fittings and structures to accommodate these off-line valves. There are basically two ways air/vacuum relief valves can be accommodated in a FLOWTITE system. The most common method is to mount the valve directly on a vertical flange nozzle. Alternatively, for heavy valves a tangential nozzle can also be designed to accommodate the assembly. Details for both arrangements follow.

Small Air/Vacuum Valves

The simplest way to accommodate small air/vacuum valves is to mount the valve directly on top a vertical flanged nozzle rising from the main below. Typically a concrete chamber houses the valve, providing safe and easy passage

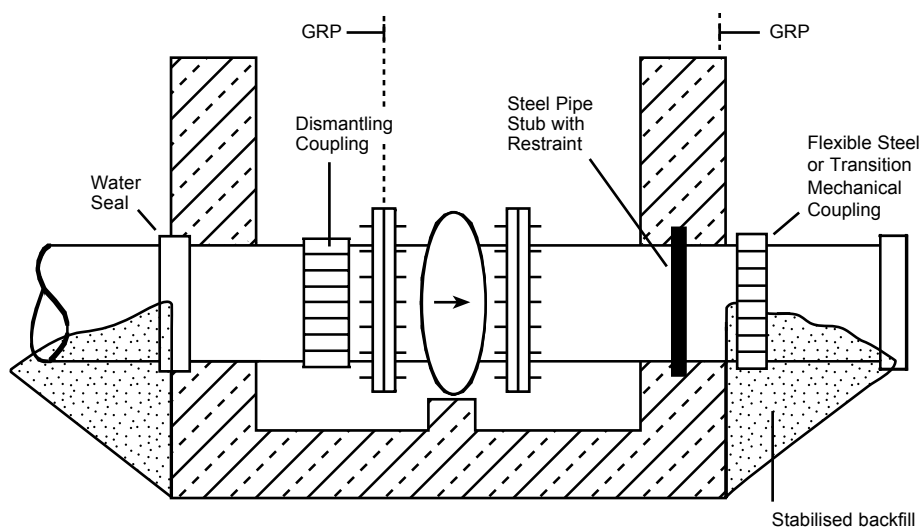

Figure 8–5 Anchoring

of air through the valve assembly. When designing and constructing the valve chamber directly over the pipe, it is important to ensure that the weight of the concrete chamber is not directly transferred to the vertical nozzle, and thus to the FLOWTITE pipe below. This can be avoided by having the vertical opening in the base of the chamber larger than the outside diameter of the FLOWTITE riser nozzle. **Figure 8–6** provides a general illustration of these desirable features.

Large Air/Vacuum Relief Valves (>100mm)

In the case of larger air/vacuum relief valves, the preferred method of installing these heavier valves is not with their weight directly bearing on the riser, but with a tangential nozzle leading to the valve installed in an adjacent chamber. The tangential nozzle can be parallel to the horizontal axis, or at a slight vertical angle (< 22.5 degrees) with an elbow. Please refer to **section 5**, Thrust Restraints, for guidance on whether a thrust block alone or a combination thrust and stress block would be required. In general, if the tangential branch pipe's diameter (chord length) is more than 50% of the diameter of the header pipe then a thrust/stress block is required. Otherwise, only a thrust block is required. **Figure 8–7** provides a general illustration of the means to accommodating large air/vacuum valve with FLOWTITE pipe.

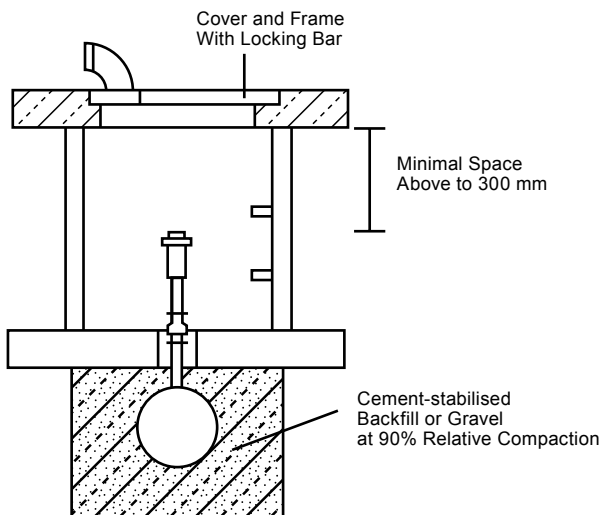

Figure 8–6 Accommodating a small diameter air/vacuum valve

8.3 Clean Out and Scour Valves

Accommodating clean outs and scour valves is similar to a large diameter air valve, only the branch nozzle is tangential to the bottom of the pipe. The same rules for thrust and thrust/stress blocks apply. If the tangential branch's pipe diameter (chord length) is more than 50% of the diameter of the header pipe then a thrust/stress block is required (section 5). Otherwise, only a thrust block is required. **Figure 8–8** gives some typical arrangements for accommodating these types of appurtenances in a FLOWTITE pressure pipeline.

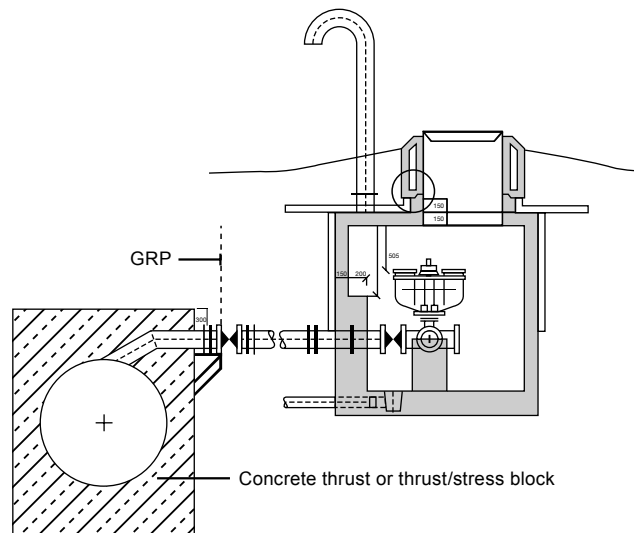

Figure 8–7 Accommodating a large diameter air/vacuum valve

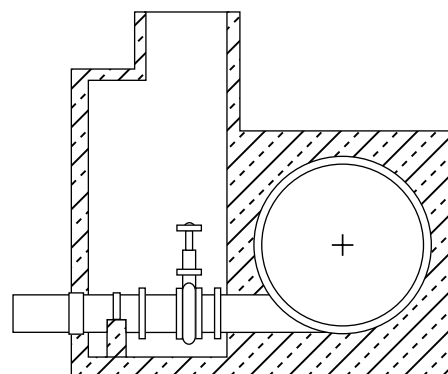

Figure 8–8 Accommodating clean out and scour valves

9 Post-Installation

- 01
- 02
- 03
- 04
- 05
- 06
- 07
- 08
- 09
- 10
- app.

9.1 Checking the Installed Pipe

Requirement: Maximum installed diametrical deflection must not exceed the values in **Table 9-1** initially. Bulges, flat areas or other abrupt changes of pipe wall curvature are not permitted. Pipes installed outside of these limitations may not perform as intended.

Checking to insure that the initial deflection requirements have been met is easy to do and should be done for each pipe immediately after completion of installation (typically within 24 hours after reaching maximum cover).

The expected initial pipe deflection after backfilling to grade level is less than 2% for most installations. A value exceeding this amount indicates that the desired quality of the installation has not been achieved and should be improved for the next pipes (i.e. increased pipe zone backfill compaction, coarser grained pipe zone backfill materials or wider trench, etc.).

Deflection measurements in each pipe installed are recommended as a good check on pipe installation quality. Never let pipe laying get too far ahead before verifying the installation quality. This will permit early detection and correction of inadequate installation methods.

Pipes installed with initial deflections exceeding the values in **Table 9-1** must be reinstalled so the initial deflection is less than those values. See section 9.2, Correcting Over-Deflected pipe, for limitations applicable to this work.

Procedure for checking the initial diametrical deflection for installed pipes:

- 1 Complete backfilling to grade.
- 2 Complete removal of temporary sheeting (if used).
- 3 Turn off the dewatering system (if used).
- 4 Measure and record the pipe's vertical diameter.
Note: For small diameter pipes, a deflection testing device (commonly called a pig) may be pulled through the pipes to measure the vertical diameter.

	Deflection % of Diameter
Large Diameter (DN ≥ 300)	3.0
Small Diameter (DN ≤ 250)	2.5

Table 9-1 Allowable Vertical Deflection

- 5 Calculate vertical deflection:

$$\% \text{ Deflection} = \frac{\text{Actual I.D.} - \text{Installed Vertical I.D.}}{\text{Actual I.D.}} \times 100$$

Actual I.D. may be verified or determined by measuring the diameters of a pipe not yet installed laying loose (no pipes stacked above) on a reasonably plane surface. Calculate as follows:

$$\text{Actual I.D.} = \frac{\text{Vertical I.D.} + \text{Horizontal I.D.}}{2}$$

(See **Figure 9-1**)

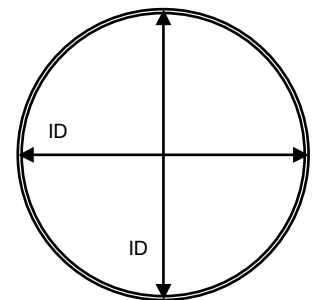

Figure 9-1
Determining actual pipe ID on pipe not yet installed

9.2 Correcting Over-Deflected Pipe

Pipes installed with initial diametrical deflections exceeding the values in **Table 9-1** must be corrected to ensure the long-term performance on the pipe.

Procedure

For pipe deflected up to 8% of diameter:

- 1 Excavate down to the haunch area, which is approximately 85% of the pipe diameter. Excavation just above and at the sides of the pipe should be done utilizing hand tools to avoid impacting the pipe with heavy equipment (**Figure 9-2**).
- 2 Inspect the pipe for damage. Damaged pipe should be repaired or replaced.
- 3 Re-compact haunch backfill, insuring it is not contaminated with unacceptable backfill material soil.
- 4 Re-backfill the pipe zone in lifts with the appropriate material, compacting each layer to the required relative compaction density.
- 5 Backfill to grade and check the pipe deflections to verify they have not exceeded the initial values in **Table 9-1**.

For pipe deflected greater than 8% pipe diameter: Pipes with over 8% deflection should be replaced completely.

! Caution: Do not attempt to jack or wedge the installed over-deflected pipe into a round condition. This may cause damage to the pipe.

If excavating multiple pipes, care must be taken to not mound the cover from one pipe over the adjacent one. The extra cover and reduction of side support could magnify an over-deflection situation.

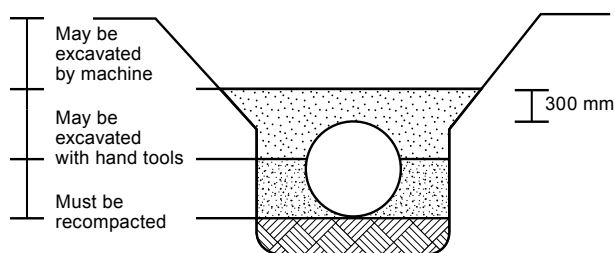

Figure 9-2 Excavating over-deflected pipe

9.3 Field Hydrotesting

Some job specifications require the completed pipe installation to be hydrostatically tested prior to acceptance and service. This is good practice as it can permit early detection and correction of some installation flaws, damaged products, etc. If a field hydrotest is specified, it must be done regularly as installation proceeds. Good construction practice would be to not exceed pipe testing with installation by more than approximately 1000 metres in order to properly assess the quality of work. The first field hydrotest should ideally include at least one air valve or drainage chamber to assess the total pipeline system. In addition to routine care, normal precautions and typical procedures used in this work, the following suggestions should be noted:

1 Preparation Prior to Test – Inspect the completed installation to assure that all work has been finished properly. Of critical importance are:

- Initial pipe deflection limited to the values in **Table 9-1**.
- Joints assembled correctly.
- System restraints (i.e., thrust blocks and other anchors) in place and properly cured.
- Flange bolting torqued per instructions.
- Backfilling completed. SEE SECTION A.6 [ON MINIMUM BURIAL DEPTH AND HIGH PRESSURE AND TESTING LIMITATIONS.](#)

- Valves and pumps anchored.
- Backfill and compaction near structures and at closure pieces has been properly carried out.

2 Filling the Line with Water – Open valves and vents, so that all air is expelled from the line during filling, and avoid pressure surges.

3 Pressurize the line slowly. Considerable energy is stored in a pipeline under pressure, and this power should be respected.

4 Ensure the gauge location will read the highest line pressure or adjust accordingly. Locations lower in the line will have higher pressure due to additional head.

5 Ensure the maximum test pressure does not exceed 1.5 x PN. Normally the field test pressure is either a multiple of the operating pressure or the operating pressure plus a small incremental amount. However, in no case should the maximum field test pressure exceed 1.5 x PN.

6 If after a brief period for stabilization the line does not hold constant pressure, ensure that thermal effect (a temperature change), system expansion or entrapped air is not the cause. If the pipe is determined to be leaking and the location is not readily apparent, the following methods may aid discovery of the problem source:

- Check flange and valve areas.
- Check line tap locations.
- Use sonic detection equipment.
- Test the line in smaller segments to isolate the leak.

9.4 Field Joint Tester

Portable hydraulic field joint test equipment can be specially ordered and supplied for diameters 800 mm and above. This equipment can be used to internally test selected pipe joints. It is required that each pipe adjacent to the joint under test be backfilled sufficiently to prevent pipe movement during testing. Additional details are available from the supplier's field Technician.

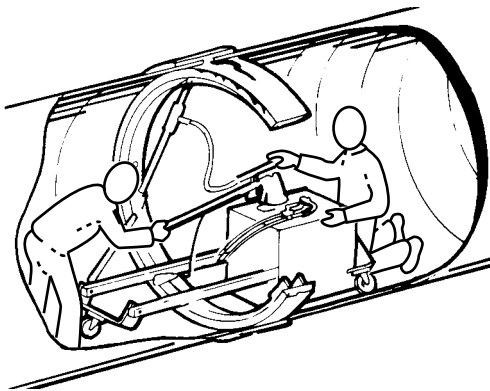

Figure 9–3 Field joint tester

! **Caution:** This equipment is designed to allow a test of the joint to verify that the joint has been assembled properly with gaskets in proper position. This equipment is limited to a maximum pressure test level of 6 bars.

9.5 Field Air Test

An alternate leak test for gravity pipe (PN 1 bar) systems may be conducted with air pressure instead of water. In addition to routine care, normal precautions and typical procedures used in this work, the following suggestions and criteria should be noted:

- 1** As with the hydrotest, the line should be tested in small segments, usually the pipe contained between adjacent manholes.
- 2** Ensure the pipeline and all materials, stubs, accesses, drops, etc. are adequately capped or plugged and braced against the internal pressure.
- 3** Slowly pressurize the system to 0.24 bar. The pressure must be regulated to prevent over pressurisation (maximum 0.35 bar).
- 4** Allow the air temperature to stabilize for several minutes while maintaining the pressure at 0.24 bar.

- 5** During this stabilization period, it is advisable to check all plugged and capped outlets with a soap solution to detect leakage. If leakage is found at any connection, release the system pressure, seal the leaky cap(s) or plug(s) and begin the procedure again at Step 3.
- 6** After the stabilization period, adjust the air pressure to 0.24 bar and shut-off or disconnect the air supply.
- 7** The pipe system passes this test if the pressure drop is 0.035 bar or less during the time periods given in **Table 9–2**.
- 8** Should the section of line under test fail the air test acceptance requirements, the pneumatic plugs can be coupled fairly close together and moved up or down the line, repeating the air test at each location, until the leak is found. This leak location method is very accurate, pinpointing the location of the leak to within one or two metres. Consequently, the area that must be excavated to make repairs is minimized, resulting in lower repair costs and considerable saved time.

! **Caution: CONSIDERABLE ENERGY IS STORED IN A PIPELINE UNDER PRESSURE. THIS IS PARTICULARLY TRUE WHEN AIR (EVEN AT LOW PRESSURES) IS THE TEST MEDIUM. TAKE GREAT CARE TO BE SURE THAT THE PIPELINE IS ADEQUATELY RESTRAINED AT CHANGES IN LINE DIRECTION AND FOLLOW MANUFACTURERS' SAFETY PRECAUTIONS FOR DEVICES SUCH AS PNEUMATIC PLUGS.**

! **Note:** This test will determine the rate at which air under pressure escapes from an isolated section of the pipeline. It is suited to determining the presence or absence of pipe damage and/or improperly assembled joints.

Diameter (mm)	Time (min.)	Diameter (mm)	Time (min.)
100	2.50	1000	25.00
150	3.75	1100	27.50
200	5.00	1200	30.00
250	6.25	1300	32.50
300	7.75	1400	35.00
350	8.75	1500	37.50
400	10.00	1600	40.00
500	12.50	1800	45.00
600	15.00	2000	50.00
700	17.50	2200	55.00
800	20.00	2400	60.00
900	22.50		

Table 9–2 Test Time – Field Air Test

10 Alternate Installations

If the burial depth requirements for the selected pipe stiffness, installation type and native soil group exceeds feasible compaction limits alternative installation procedures must be considered.

Three alternative installation methods are available:

- Wider Trench
- Permanent Sheet piling (see section 7.5 →)
- Stabilised Backfill (Cement)

10.1 Wide Trench

Increasing the trench width distances the poor native soil farther from the pipe allowing a deeper installation and higher allowable negative pressure (vacuum).

10.2 Cement Stabilised Backfill

Scope

Cement is mixed with moist sandy soil, and the mixture placed and compacted as a typical backfill soil. The amount of type 3 Portland cement added to the sandy soil is approximately 4 to 5 parts per hundred weight of the soil. The moisture level should be in the range of 5 to 10%. The compaction density required is dependent on the cover depth prior to allowing the stabilised backfill to set. If the desired cover depth is small, the required density is low. The cement-stabilised backfill can set in one or two days and the cover fill can be placed to grade, with a maximum total cover depth of 5 metres.

Mixture

100 parts soil (dry weight), 4 to 5 parts type 3 Portland cement, and 12% water (+/-6%). Account for the natural moisture content of the soil when adding water. The soil can be type SC2 or SC3. Type SC2 soil is the easiest to mix; however, the other type may be used. Mixing can be accomplished on the ground by spreading a layer of backfill soil and a thin layer of cement over it, and then mixing the two together. The mixing can be done by hand, with a hoe, or mechanically with any appropriate device. The backfill should be placed within two hours of mixing.

Compaction

The cement-stabilised backfill will achieve a high stiffness without the need for significant compaction. Be sure to place a backfill under the pipe haunches and compact with a haunch-compaction tool. A Whacker compactor is required to compact the cement-stabilised backfill next to the pipe. One pass of the compactor with 300 mm lifts is sufficient for most conditions in which the cover depth is less than 2 metres. Check the pipe deflection to assure the compaction is adequate to support the pipe. If initial deflection exceeds 2.5%, increase the amount of compaction or use less cover until the cement-stabilised backfill sets in one or two days. If a significant depth of cover is to be placed before the cement-stabilised backfill is allowed to set, a higher level of compaction is required to prevent excessive pipe deflection. Keep the initial deflection to no more than 2.5%. The amount of compaction effort required is dependent on cover depth, lift height and specific soil used in the mixture.

It is also recommended that a stabilised backfill be used in the immediate vicinity of large thrust blocks, or valve chambers and in areas of significant over-excavation.

01

02

03

04

05

06

07

08

09

10

app.

Appendix AWWA M 45

Appendix A	Installation Design	40
A.1	Design Principles	40
A.2	Native Soil Stiffness Groups	42
A.3	Backfill Constrained Modulus, M_{sb}	42
A.4	Trench Width	44
A.5	Negative Pressure	44
A.6	Burial Limitation – Minimum	45
A.7	Seismic Loading	45
A.8	Backfill Migration	46
Appendix B	Installation Tables	46
Appendix C	Classification and Properties of Native Soils	62
Appendix D	Classification and Properties of Backfill Soils	63
Appendix E	Field Testing to assist Classification of Native Soils	65
Appendix F	Compaction of Backfill	65
Appendix G	Definitions and Terminology	67
Appendix H	Approximate Weights for Pipes and Couplings	68
Appendix I	Joint Lubricant Requirements	69
Appendix J	Cleaninig of Flowtite Sewer Pipe	69

01

02

03

04

05

06

07

08

09

10

app.

Appendix A Installation Design

The long life and good performance of FLOWTITE pipe is ensured by proper handling and installation. FLOWTITE pipes are flexible and allow the designer to utilize the bedding and pipe zone backfill for support. Together the pipe and embedment material form a “pipe-soil system” that provides proven long-term performance.

The two most widely accepted design methodologies regarding the installation design of GRP pipes are based on the work of the Abwassertechnischen Vereinigung (ATV) of Germany and the American Water Works Association (AWWA). Both of these methods have been successfully used for decades. This Appendix is based on the current AWWA approach.

A.1 Design Principles

A flexible pipe like FLOWTITE will deflect when subjected to soil and traffic loads. When deflected the increase of the pipe horizontal diameter will develop passive soil resistance counteracting the deflection. The amount of deflection needed to generate sufficient earth pressure to resist any given load will primarily depend on the stiffness of the backfill material and native soil as well as trench width. The initial deflection of the pipe measured after backfilling to level can therefore be considered as a direct indicator of the quality of the pipe installation.

Settlement and consolidation of the soil surrounding the pipe will result in an increase of the pipe deflection over time. Almost all of the increase in deflection will take place during the first 1 to 2 years after installation. After that the deflection will stabilize.

The initial deflections must not exceed the values given in Table A–1. Pipes installed outside these limits may not perform as intended.

The type of installation appropriate for FLOWTITE pipe

	Deflection % of Diameter
Large Diameter (DN ≥ 300)	3.0
Small Diameter (DN ≤ 250)	2.5

Table A–1 Allowable Vertical Deflection

varies with native soil characteristics, cover depth, loading conditions and available backfill materials. The native soil and backfill material must adequately confine the pipe to achieve proper pipe support.

The support of the surrounding soil is defined in terms of the constrained or one dimensional soil modulus, M_s , at pipe elevation. To determine M_s for a buried pipe, separate M_s values for native soil, M_{sn} , and the pipe backfill surround, M_{sb} , must be determined and then combined depending on the trench width.

The most important installation design parameters are indicated in **Figure A–1**. The native soil stiffness, burial depth, groundwater level, life load and internal vacuum must be determined according to the conditions along the route of the planned pipe installation. Based upon this information and available backfill material, backfill compaction, trench width and pipe stiffness is selected.

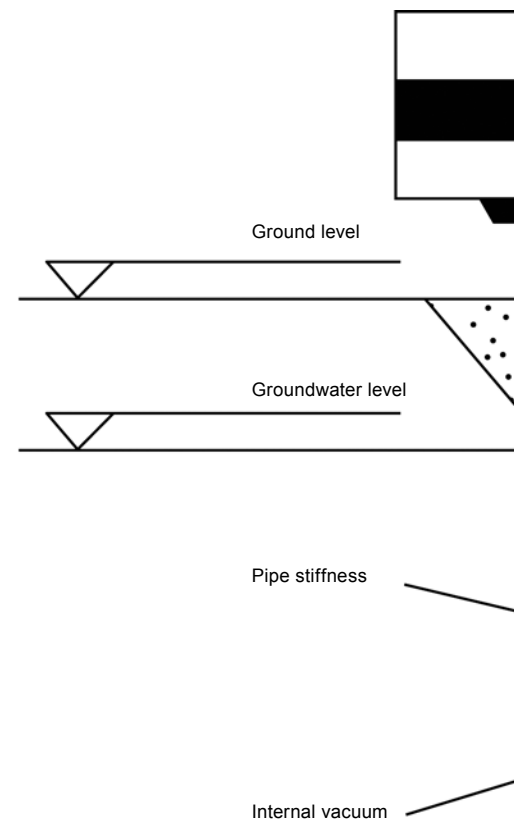

Pipe installation design tables showing minimum backfill compaction are given in Appendix B [→](#). The most commonly encountered installation and operating conditions are covered. Tables are provided for selected combinations of 1) groundwater level, 2) traffic load, 3) internal vacuum and 4) trench width.

The tables show minimum backfill compaction at different burial depths for all practical combination of backfill materials, native soils and pipe stiffness. All of the tables are valid for working pressure anywhere in the range from atmospheric to nominal pressure of the pipe.

The expected initial pipe deflection is less than 2 % for most installations given in Appendix B. Therefore, while initial deflections in **Table A-1** are acceptable for the pipe performance, a value exceeding the expected amount indicates the installation intended has not been achieved and should be improved for the next pipes (i.e. increased

pipe zone backfill compaction, coarser grained pipe zone backfill materials or wider trench, etc.).

Appendices from C through G give information on both native and backfill soils.

- **Appendix C** – Classification and Properties of Native Soils
- **Appendix D** – Classification and Properties of Backfill Soils
- **Appendix E** –Field Testing to assist Classification of Native Soils
- **Appendix F** – Compaction of Backfill
- **Appendix G** – Definitions and Terminology

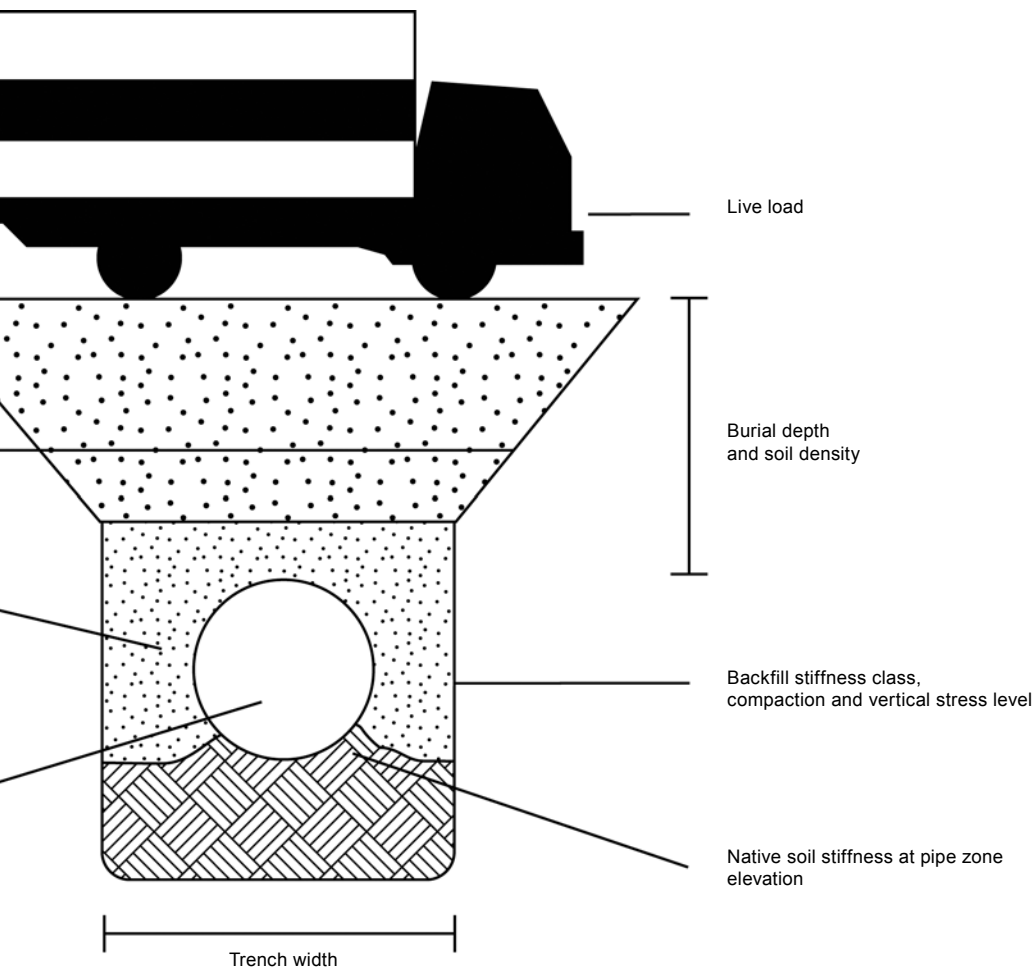

Figure A-1 Installation Design Parameters

A.2 Native Soil Stiffness Groups

The support of the native soil is defined in terms of the constrained or one dimensional soil modulus M_{sn} at pipe elevation. For design of pipe installations, native soils are grouped in stiffness groups. In **Table A-2** are brief descriptions of the native soil stiffness groups. Appendix C gives detailed definitions for native soil groups [→](#).

Testing of native soil should be done frequently and particularly where changes are suspected. Properties of importance are those obtained at the bed and pipe zone elevation. The blow counts or soil strengths must represent the most severe (weakest) condition expected to exist for any significant period of time. (Normally this occurs when the water table is at its highest elevation.)

A.3 Backfill Constrained Modulus, M_{sb}

The measure of the level of backfill soil support is expressed as the constrained soil modulus M_{sb} in MPa. For design of pipe installations, suitable backfill soils are classified in 4 different stiffness categories, SC1, SC2, SC3 and SC4.

A brief description of the backfill stiffness categories is given in **Table A-3**

For any given backfill stiffness category, the higher the compaction the higher the soil modulus and the higher the support. In addition, the soil modulus also increases with the vertical soil stress level, i.e. with burial depth.

Table A-4 to **Table A-7** give the M_{sb} values for backfill stiffness categories SC1, SC2, SC3 and SC4 as a function of the % Standard Proctor Density (SPD) and vertical stress level. The values apply to pipes installed above the groundwater level. For pipes installed below groundwater level, the constrained soil modulus will be reduced for lower stiffness class soils and lower compaction, see values in parenthesis. The vertical stress level is the vertical effective soil stress at the pipe springline elevation. It is normally computed as the design soil unit weight times the depth of fill. Buoyant unit weight should be used below the groundwater level.

For description of backfill soil stiffness categories, see Appendix D [→](#).

Soil group	Granular		Cohesive		Modulus M_{sn}
	Blow count ¹	Description	q_u kPa	Description	
1	> 15	Compact	> 200	Very stiff	34.50
2	8 - 15	Slightly compact	100 - 200	Stiff	20.70
3	4 - 8	Loose	50 - 100	Medium	10.30
4	2 - 4		25 - 50	Soft	4.80
5	1 - 2	Very loose	13 - 25	Very soft	1.40
6	0 - 1	Very very loose	0 - 13	Very very soft	0.34

¹ Standard penetration test per ASTM D1586

Table A-2 Native Soil Stiffness Groups. Values of Constrained Modulus, M_{sn}

Backfill Soil Stiffness Category	Description of Backfill Soils
SC1	Crushed rock with < 15% sand, maximum 25% passing the 9.5 mm sieve and maximum 5% fines ² .
SC2	Clean, coarse-grained soils: SW, SP ¹), GW, GP or any soil beginning with one of these symbols with 12% or less fines ² .
SC3	Clean, coarse-grained soils with fines: GM, GC, SM, SC or any soil beginning with one of these symbols with 12% or more fines ² . Sandy or gravely fine-grained soils: CL, ML, (or CL-ML, CL/ML, ML/CL) with 30% or more retained on a no. 200 sieve
SC4	Fine grained soils: CL, ML, (or CL-ML, CL/ML, ML/CL) with 30% or less retained on a no. 200 sieve

Note: Symbols in table are according to the Unified Soil Classification Designation, ASTM D2487
 1) Uniform fine sand, SP, with more than 50% passing no. 100 sieve (0.15 mm) is very sensitive to moisture and is not recommended as backfill.
 2) % fines is the weight percentage of soil particles that pass no. 200 sieve with 0.076 mm opening

Table A-3 Backfill Soil Type Classification

Burial Depth (Soil Density 18.8 kN/m ³)	Vertical Stress Level	Compaction, % maximum Standard Proctor Density	
		Compacted	Dumped
m	kPa	MPa	MPa
0.4	6.9	16.2	13.8
1.8	34.5	23.8	17.9
3.7	69.0	29.0	20.7
7.3	138.0	37.9	23.8
14.6	276.0	51.7	29.3
22.0	414.0	64.1	34.5

Table A-4 M_{sb} for SC1 Backfill Soil

Burial Depth (Soil Density 18.8 kN/m ³)	Vertical Stress Level	Compaction, % maximum Standard Proctor Density			
		100	95	90	85
m	kPa	MPa	MPa	MPa	MPa
0.4	6.9	16.2	13.8	8.8 (7.5)	3.2 (2.4)
1.8	34.5	23.8	17.9	10.3 (8.8)	3.6 (2.7)
3.7	69.0	29.0	20.7	11.2 (9.5)	3.9 (2.9)
7.3	138.0	37.9	23.8	12.4 (10.5)	4.5 (3.4)
14.6	276.0	51.7	29.3	14.5 (12.3)	5.7 (4.3)
22.0	414.0	64.1	34.5	17.2 (14.6)	6.9 (5.2)

Table A-5 M_{sb} for SC2 Backfill Soil (reduced values below ground water table in parenthesis)

Burial Depth (Soil Density 18.8 kN/m ³)	Vertical Stress Level	Compaction, % maximum Standard Proctor Density			
		100	95	90	85
m	kPa	MPa	MPa	MPa	MPa
0.4	6.9	-	9.8 (4.9)	4.6 (2.3)	2.5 (1.3)
1.8	34.5	-	11.5 (5.8)	5.1 (2.6)	2.7 (1.4)
3.7	69.0	-	12.2 (6.1)	5.2 (2.6)	2.8 (1.4)
7.3	138.0	-	13.0 (6.5)	5.4 (2.7)	3.0 (1.5)
14.6	276.0	-	14.4 (7.2)	6.2 (3.1)	3.5 (1.8)
22.0	414.0	-	15.9 (8.0)	7.1 (3.6)	4.1 (2.1)

Table A-6 M_{sb} for SC3 Backfill Soil (values below ground water level in parenthesis)

Burial Depth (Soil Density 18.8 kN/m ³)	Vertical Stress Level	Compaction, % maximum Standard Proctor Density			
		100	95	90	85
m	kPa	MPa	MPa	MPa	MPa
0.4	6.9	-	3.7 (1.11)	1.8 (0.54)	0.9 (0.27)
1.8	34.5	-	4.3 (1.29)	2.2 (0.66)	1.2 (0.36)
3.7	69.0	-	4.8 (1.44)	2.5 (0.75)	1.4 (0.42)
7.3	138.0	-	5.1 (1.53)	2.7 (0.81)	1.6 (0.48)
14.6	276.0	-	5.6 (1.68)	3.2 (0.96)	2.0 (0.60)
22.0	414.0	-	6.2 (1.86)	3.6 (1.08)	2.4 (0.72)

Table A-7 M_{sb} for SC4 Backfill Soil (values below ground water level in parenthesis)

- ! **Note:** M_{sb} values at intermediate vertical stress levels not given in **Table A-4** to **Table A-7** can be obtained by interpolation.
- ! **Note:** The % maximum standard proctor density indicates the dry density of the compacted soil as a percentage of maximum dry density determined in accordance with ASTM D 698.

A.4 Trench Width

The soil support for a buried pipe installation, expressed as the composite constrained soil modulus, M_s , depends on the constrained modulus of both the backfill and native soil, M_{sb} and M_{sn} , as well as the trench width.

For pipe installation in soft native soils where M_{sn} is lower than M_{sb} , the composite modulus, M_s , will be lower than the backfill modulus, M_{sb} . This effect is less pronounced for wider trenches and can be disregarded for trenches wider than 5 times the pipe diameter at elevation of the pipe springline. This means that a wider trench provides for better soil support.

For installations in firm native soils where M_{sn} is higher than M_{sb} , the composite modulus will be higher than the backfill modulus. This effect will be less pronounced for a wider trench, which in this case will provide less soil support.

The trench must always be wide enough to allow for adequate space to ensure proper placement and compaction of backfill in the haunch region. It must also be wide enough to safely operate compaction equipment without damaging the pipe.

A.5 Negative Pressure

In order to provide proper soil stabilizing support, a minimum burial depth of 1.0 metre is recommended for negative pressure (vacuum) situations where the negative pressure is in excess of 0.25 bar for SN2500, 0.5 bar for SN5000 pipes.

The maximum allowable negative pressure (vacuum) in the pipe is a function of burial depth, native soil, pipe and backfill soil stiffness as well as trench width. See Appendix B [→](#) for backfill compaction requirement for conditions with vacuum in the pipe.

Unburied Pipe Sections

Some sections of a buried pipeline, such as in valve pits or chambers, may be non-soil supported. As the stabilizing support of the soil is not present the negative pressure capability has to be evaluated separately. **Table A-8** gives the maximum allowable negative pressure for lengths between restraints of 3, 6 and 12 metres.

DN mm	SN 2500			SN 5000			SN 10000		
	3 m	6 m	12 m	3 m	6 m	12 m	3 m	6 m	12 m
100	-	-	-	-	-	-	1.00	1.00	-
150	-	-	-	-	-	-	1.00	1.00	-
200	-	-	-	-	-	-	1.00	1.00	-
250	-	-	-	-	-	-	1.00	1.00	-
300	0.28	0.25	0.25	0.53	0.50	0.50	1.00	1.00	1.00
350	0.30	0.25	0.25	0.55	0.50	0.50	1.00	1.00	1.00
400	0.32	0.25	0.25	0.58	0.50	0.50	1.00	1.00	1.00
450	0.32	0.26	0.25	0.61	0.51	0.50	1.00	1.00	1.00
500	0.39	0.26	0.25	0.66	0.51	0.50	1.00	1.00	1.00
600	0.48	0.27	0.25	0.78	0.52	0.50	1.00	1.00	1.00
700	0.66	0.28	0.25	1.00	0.54	0.50	1.00	1.00	1.00
800	0.74	0.30	0.25	1.00	0.56	0.50	1.00	1.00	1.00
900	0.77	0.32	0.25	1.00	0.59	0.50	1.00	1.00	1.00
1000	0.82	0.36	0.26	1.00	0.64	0.51	1.00	1.00	1.00
1200	0.95	0.46	0.26	1.00	0.77	0.52	1.00	1.00	1.00
1400	1.00	0.62	0.28	1.00	0.98	0.53	1.00	1.00	1.00
1600	1.00	0.73	0.29	1.00	1.00	0.56	1.00	1.00	1.00
1800	1.00	0.77	0.32	1.00	1.00	0.59	1.00	1.00	1.00
2000	1.00	0.81	0.35	1.00	1.00	0.63	1.00	1.00	1.00
2400	1.00	0.94	0.45	1.00	1.00	0.76	1.00	1.00	1.00

Table A-8 Maximum Allowable Negative Pressure (bars) for Unburied Sections
– Pipe Length between Restraints 3 m / 6 m / 12 m

A.6 Burial Limitation – Minimum

General

Minimum recommended burial depth for pipes with operating pressures of 10 bars or less is 0.5 metres provided that pipes are joined without vertical joint deflection. For operating and installation conditions involving traffic load, negative pressure, high pressure, high water table or frost, see requirements in the following sections.

Traffic Loading

In situations where pipes are to be buried under a roadway, or continuing traffic loading is anticipated, the backfill material should be compacted to grade level. Consult road construction codes of practice for local requirements and recommendations. Minimum cover restrictions may be reduced with special installations such as concrete encasement, concrete cover slabs, castings, etc.

The installation tables in Appendix B are based on an assumed AASHTO HS20 load. In general a minimum burial depth of 1.0 metre is recommended good practice for traffic loading using well compacted granular soils as backfill.

Table A–9 shows the minimum burial depth for other traffic loadings.

Load Type	Traffic (Wheel) Load (kN)	Minimum Cover Depth (meters)
ATV LKW 12	40	0.6
ATV SLW 30	50	0.6
AASHTO HS20	72	0.8
AASHTO HS25	90	1.0
BS153 HA	90	1.0
ATV SLW 60	100	1.0
MOC	160	1.5
Cooper E80 Railroad Engine		3.0

Table A–9 Minimum Cover Depths with Traffic Load in Standard Conditions

Construction Traffic Loading

In some cases large, heavy earth moving equipment or construction cranes may be present in or near the pipe installation area. These types of equipment can result in very high localized surface loads. The effects of such loading must be evaluated on a case by case basis to establish proper procedures and limits.

Negative Pressure

A minimum burial depth of 1.0 metre is recommended for negative pressure (vacuum) situations where the negative pressure is in excess of 0.25 bar for SN2500, 0.5 bar for SN5000 pipes.

High Pressure

High pressures require consideration of the possible uplift forces at joints both during operation and any field hydrotesting.

For operating pressures of 16 bar and greater the minimum burial depth should be 1.2 metres for pipes of DN 300 mm and larger and 0.8 meters for pipes of DN less than 300 mm. During field hydrotesting at pressures below 16 bars the couplings should be backfilled at least to the crown with pipes backfilled to the minimum cover depth. During field hydrotesting at pressures 16 bar and greater: For pipes in straight alignment backfill to the crown of the coupling or higher before performing the field hydrotest. Pipes must be backfilled to minimum cover. For pipes installed with angular deflection both the pipe and the coupling must be covered to the final grade before the field pressure test.

High Water Table

A minimum of 0.75 diameter of earth cover (minimum dry soil bulk density of 19 kN/m³) is required to prevent an empty submerged pipe from floating.

Alternatively, the installation may proceed by anchoring the pipes. If anchoring is proposed, restraining straps must be a flat material, minimum 25 mm wide, placed at maximum 4.0 metres intervals. Consult the manufacturer for details on anchoring and minimum cover depth with anchors.

Frost Line

The minimum cover depth for FLOWTITE pipe, as any other pipe material, should be such that the pipe is buried BELOW the anticipated frost level, or consult the local construction codes of practice for other techniques when installing the pipe within the frost level.

A.7 Seismic Loading

Because of their flexibility FLOWTITE pipes have demonstrated excellent seismic behaviour. The structural analysis of pipes under earthquake loading is site specific, where moment magnitude, soil characteristics and the probability of the event are the main input. Consult your supplier for specific design considerations and analysis.

A.8 Backfill Migration

When open graded material is placed adjacent to a finer material, fines may migrate into the coarser material under the action of hydraulic gradient from groundwater flow. Significant hydraulic gradients may arise in the pipeline trench during construction, when water levels are controlled by pumping, or after construction, when permeable underdrain or embedment materials act as a drain under high ground water levels. Field experience shows that migration can result in significant loss of pipe support and increase of deflections.

The gradation and relative size of the embedment and adjacent materials must be compatible in order to minimize migration. In general, where significant groundwater flow is anticipated, avoid placing coarse, open-graded material, such as SC1, below or adjacent to finer material unless methods are employed to impede migration. Consider the use of an appropriate soil filter or a geotextile filter fabric along the boundary of incompatible materials. The following filter gradation criteria may be used to restrict migration of fines into the voids of coarser material under hydraulic gradient:

- $D_{15}/d_{85} < 5$ where D_{15} is the sieve opening size passing 15 percent by weight of the coarser material and d_{85} is the sieve opening size passing 85 percent by weight of the finer material.
- $D_{50}/d_{50} < 25$ where D_{50} is the sieve opening size passing 50 percent by weight of the coarser material and d_{50} is the sieve opening size passing 50 percent by weight of the finer material. This criterion need not apply if the coarser material is well graded (see ASTM D 2487).

If the finer material is a medium to highly plastic clay (CL or CH), then the following criterion may be used in lieu of the D_{15}/d_{85} criteria: $D_{15} < 0.5$ mm where D_{15} is the sieve opening size passing 15 percent by weight of the coarser material.

The aforementioned criteria may need to be modified if one of the materials is gap graded. Materials selected for use based on filter gradation criteria should be handled and placed in a manner that will minimize segregation.

Where incompatible materials must be used, they must be separated by filter fabric designed to last the life of the pipeline to prevent wash-away and migration. The filter fabric must completely surround the bedding and pipe zone backfill material and must be folded over the pipe zone area in order to prevent contamination of the selected backfill material.

Appendix B Installation Tables

Pipe installation design tables showing minimum backfill compaction are given in this Appendix. The minimum backfill compaction is given at different burial depths for all practical combinations of backfill stiffness category, native soil stiffness group and pipe stiffness. Both standard, $B_d/D = 1.8$ and wide, $B_d/D = 3.0$, trenches are covered. Tables are provided for selected combinations of 1) groundwater level, 2) traffic load and 3) internal vacuum. All of the tables are valid for working pressure anywhere in the range from atmospheric to nominal pressure of the pipe.

The minimum backfill compaction is expressed as percent standard proctor density for backfill soil categories SC2, SC3 and SC4. For crushed rock as backfill, SC1, the minimum compaction is expressed either as dumped, D, or compacted, C. Note that SC1 backfill material also has to be worked into the haunch zone for installation conditions where compaction is otherwise not required.

The compaction values recommended are to be considered as a minimum values and field densities should be at or higher than the requirement. Include considerations for seasonal variations when assessing the potential for moisture content of both in situ and backfill soils. The backfill compaction tables are calculated following the current approach of AWWA assuming the soil and bedding properties listed below:

- Deflection lag factor, $DL = 1.5$
- Dry unit weight of overburden, $gs, dry = 18.8$ kN/m³
- Wet (buoyant) unit weight of overburden, $gs, wet = 11.5$ kN/m³
- Bedding coefficient (typical direct bury condition), $k_x = 0.1$

Backfill compaction tables have been calculated for the loading and installation conditions listed in **Table B-1**, **Table B-2** and **Table B-3**.

Table B-1 shows combinations calculated for large diameter pipes, $DN \geq 300$ mm, to be installed with backfill configuration Type 1, see **Figure 3-4** .

! Note: For installations where both traffic load and vacuum can occur, use the highest compaction requirement of **Table B-5** and **Table B-6** for installations with groundwater below pipe and the highest of **Table B-8** and **Table B-9** for installation with groundwater to level.

Traffic Load	Internal Vacuum	Ground Water	Trench Width at Pipe Springline	Installation Table
AASTHO	bar		B _d /D	
0	0	Below pipe	1.8 and 3.0	Table B-4
HS 20	0	Below pipe	1.8 and 3.0	Table B-5
0	1	Below pipe	1.8 and 3.0	Table B-6
0	0	To level	1.8 and 3.0	Table B-7
HS 20	0	To level	1.8 and 3.0	Table B-8
0	1	To level	1.8 and 3.0	Table B-9

Table B-1 Load Combinations for Type 1 Installation of DN ≥ 300 mm Pipes

Table B-2 shows combinations calculated for small diameter pipes, DN ≤ 250 mm, to be installed with backfill configuration Type 1, see Figure 3-4 →.

Traffic Load	Internal Vacuum	Ground Water	Trench Width at Pipe Springline	Installation Table
AASTHO	bar		B _d /D	
0	0	Below pipe	1.8 and 3.0	Table B-10
HS 20	0	Below pipe	1.8 and 3.0	Table B-10
0	1	Below pipe	1.8 and 3.0	Table B-10
0	0	To level	1.8 and 3.0	Table B-11
HS 20	0	To level	1.8 and 3.0	Table B-11
0	1	To level	1.8 and 3.0	Table B-11

Table B-2 Load Combinations for Type 1 Installation of DN ≤ 250 mm Pipes

! **Note:** For installations where both traffic load and vacuum can occur, use the highest compaction requirement of the two load cases.

Table B-3 shows combinations calculated for large diameter pipes, DN ≥ 300 mm, to be installed with backfill configuration Type 2 (split), see Figure 3-5 →.

Internal Vacuum	Ground Water	Trench Width at Pipe Springline	Backfill Below 0.6xDN	Backfill Above 0.6xDN		Installation Table
bar		B _d /D	Category	Category	% SPD	
0	Below pipe	1.8 and 3.0	SC1, SC2	SC3	85	Table B-12
0	Below pipe	1.8 and 3.0	SC1, SC2	SC4	90	Table B-12
0.5	Below pipe	1.8 and 3.0	SC1, SC2	SC3	85	Table B-13
0.5	Below pipe	1.8 and 3.0	SC1, SC2	SC4	90	Table B-13
1	Below pipe	1.8 and 3.0	SC1, SC2	SC3	85	Table B-14
1	Below pipe	1.8 and 3.0	SC1, SC2	SC4	90	Table B-14
0	To level	1.8 and 3.0	SC1, SC2	SC3	85	Table B-15
0	To level	1.8 and 3.0	SC1, SC2	SC4	95	Table B-15
0.5	To level	1.8 and 3.0	SC1, SC2	SC3	85	Table B-16
0.5	To level	1.8 and 3.0	SC1, SC2	SC4	95	Table B-16
1	To level	1.8 and 3.0	SC1, SC2	SC3	85	Table B-17
1	To level	1.8 and 3.0	SC1, SC2	SC4	95	Table B-17

Table B-3 Load Combinations for Type 2 Installation of DN ≥ 300 mm Pipes

For other installation and/or operating conditions, consult the appropriate AWWA or ATV installation design documents.

01
02
03
04
05
06
07
08
09
10
app.

Type 1 DN ≥ 300		No Traffic Load – No Internal Vacuum – Ground Water Below Pipe Invert																								<= Native Soil
Backfill	Pipe SN	Standard Trench, Bd/D = 1.8												Wide Trench, Bd/D = 3.0												
		SC1			SC2			SC3			SC4			SC1			SC2			SC3			SC4			
Burial Depth, m		2500	5000	10000	2500	5000	10000	2500	5000	10000	2500	5000	10000	2500	5000	10000	2500	5000	10000	2500	5000	10000	2500	5000	10000	
1.0		D	D	D	85	85	85	85	85	85	90	90	90	D	D	D	85	85	85	85	85	85	90	90	90	
1.5		D	D	D	85	85	85	85	85	85	90	90	90	D	D	D	85	85	85	85	85	85	90	90	90	
2.0		D	D	D	85	85	85	85	85	85	90	90	90	D	D	D	85	85	85	85	85	85	90	90	90	
3.0		D	D	D	85	85	85	85	85	85	90	90	90	D	D	D	85	85	85	85	85	85	90	90	90	
5.0		D	D	D	85	85	85	85	85	85	90	90	90	D	D	D	85	85	85	85	85	85	95	95	90	
8.0		D	D	D	85	85	85	85	85	85	95	95	95	D	D	D	90	90	90	90	90	90	95	95	95	
12.0		D	D	D	90	90	85	90	90	85			95	D	D	D	90	90	90	95	95	95				
20.0		D	D	D	90	90	90	95	95	95				D	D	D	90	90	90			95				
30.0		C	C	C	95	95	95							C	C	C	95	95	95							
1.0		D	D	D	85	85	85	85	85	85	90	90	90	D	D	D	85	85	85	85	85	85	90	90	90	
1.5		D	D	D	85	85	85	85	85	85	90	90	90	D	D	D	85	85	85	85	85	85	90	90	90	
2.0		D	D	D	85	85	85	85	85	85	90	90	90	D	D	D	85	85	85	85	85	85	90	90	90	
3.0		D	D	D	85	85	85	85	85	85	90	90	90	D	D	D	85	85	85	85	85	85	90	90	90	
5.0		D	D	D	85	85	85	85	85	85	90	90	90	D	D	D	85	85	85	85	85	85	95	95	90	
8.0		D	D	D	85	85	85	85	85	85	95	95	95	D	D	D	90	90	90	95	90	90			95	
12.0		D	D	D	90	90	90	95	95	90				D	D	D	90	90	90	95	95	95				
20.0		C	D	D	95	90	90			95				C	C	C	95	95	95							
30.0		C	C	C	100	100	100							C	C	C	95	95	95							
1.0		D	D	D	85	85	85	85	85	85	90	90	90	D	D	D	85	85	85	85	85	85	90	90	90	
1.5		D	D	D	85	85	85	85	85	85	90	90	90	D	D	D	85	85	85	85	85	85	90	90	90	
2.0		D	D	D	85	85	85	85	85	85	90	90	90	D	D	D	85	85	85	85	85	85	90	90	90	
3.0		D	D	D	85	85	85	85	85	85	90	90	90	D	D	D	85	85	85	85	85	85	90	90	90	
5.0		D	D	D	85	85	85	85	85	85	90	90	90	D	D	D	85	85	85	85	85	85	95	95	95	
8.0		D	D	D	90	90	85	90	90	85	95	95	95	D	D	D	90	90	90	95	95	95				
12.0		D	D	D	90	90	90	95	95	95				D	D	D	90	90	90	95	95	95				
20.0		C	C	C	100	100	100							C	C	C	95	95	95							
30.0		C	C	C	100	100	100							C	C	C	100	95	95							
1.0		D	D	D	85	85	85	85	85	85	90	90	90	D	D	D	85	85	85	85	85	85	90	90	90	
1.5		D	D	D	85	85	85	85	85	85	90	90	90	D	D	D	85	85	85	85	85	85	90	90	90	
2.0		D	D	D	85	85	85	85	85	85	90	90	90	D	D	D	85	85	85	85	85	85	90	90	90	
3.0		D	D	D	85	85	85	85	85	85	90	90	90	D	D	D	85	85	85	85	85	85	90	90	90	
5.0		D	D	D	85	85	85	85	85	85	95	95	90	D	D	D	90	85	85	90	85	85	95	95	95	
8.0		C	D	D	95	90	90	95	95	95				D	D	D	90	90	90	95	95	95				
12.0		C	C	C	100	100	95							D	D	D	90	90	90	95	95	95				
20.0														C	C	C	95	95	95							
30.0														C	C	C	100	100	100							
1.0		D	D	D	85	85	85	85	85	85	90	90	90	D	D	D	85	85	85	85	85	85	90	90	90	
1.5		D	D	D	90	85	85	90	85	85	95	90	90	D	D	D	85	85	85	85	85	85	90	90	90	
2.0		D	D	D	90	90	85	95	90	85				D	D	D	85	85	85	85	85	85	90	90	90	
3.0		C	C	D	95	95	90			95				D	D	D	90	85	85	90	85	85	95	95	90	
5.0				C			100							D	D	D	90	90	90	95	95	95			95	
8.0														C	D	D	95	90	90			95	95			
12.0														C	C	C	95	95	95							
20.0														C	C	C	100	100	100							
30.0														C	C	C	100	100	100							

Table B-4 Installation Type 1, DN ≥ 300. Ground Water below Pipe Invert
Minimum Backfill Compaction, % Standard Proctor Density. (D = Dumped, C = Compacted)

Type 1 DN ≥ 300		Traffic Load AASHTO HS 20 – No Internal Vacuum – Ground Water Below Pipe Invert																								
		Standard Trench, Bd/D = 1.8												Wide Trench, Bd/D = 3.0									≤ Native Soil			
Backfill		SC1			SC2			SC3			SC4			SC1			SC2			SC3				SC4		
Pipe SN																										
Burial Depth, m		2500	5000	10000	2500	5000	10000	2500	5000	10000	2500	5000	10000	2500	5000	10000	2500	5000	10000	2500	5000	10000		2500	5000	10000
1.0		D	D	D	85	85	85	85	85	85				D	D	D	85	85	85	85	85	85				
1.5		D	D	D	85	85	85	85	85	85				D	D	D	85	85	85	85	85	85				
2.0		D	D	D	85	85	85	85	85	85				D	D	D	85	85	85	85	85	85				
3.0		D	D	D	85	85	85	85	85	85				D	D	D	85	85	85	85	85	85				
5.0		D	D	D	85	85	85	85	85	85				D	D	D	85	85	85	85	85	85				
8.0		D	D	D	85	85	85	85	85	85				D	D	D	90	90	90	90	90	90				
12.0		D	D	D	90	90	85	90	90	85				D	D	D	90	90	90	95	95	95				
20.0		D	D	D	90	90	90	95	95	95				D	D	D	90	90	90			95				
30.0		C	C	C	95	95	95							C	C	C	95	95	95							
1.0		D	D	D	85	85	85	85	85	85				D	D	D	85	85	85	85	85	85				
1.5		D	D	D	85	85	85	85	85	85				D	D	D	85	85	85	85	85	85				
2.0		D	D	D	85	85	85	85	85	85				D	D	D	85	85	85	85	85	85				
3.0		D	D	D	85	85	85	85	85	85				D	D	D	85	85	85	85	85	85				
5.0		D	D	D	85	85	85	85	85	85				D	D	D	85	85	85	85	85	85				
8.0		D	D	D	85	85	85	85	85	85				D	D	D	90	90	90	95	90	90				
12.0		D	D	D	90	90	90	95	95	90				D	D	D	90	90	90	95	95	95				
20.0		C	D	D	95	90	90			95				C	C	C	95	95	95							
30.0		C	C	C	100	100	100							C	C	C	95	95	95							
1.0		D	D	D	85	85	85	85	85	85				D	D	D	85	85	85	85	85	85				
1.5		D	D	D	85	85	85	85	85	85				D	D	D	85	85	85	85	85	85				
2.0		D	D	D	85	85	85	85	85	85				D	D	D	85	85	85	85	85	85				
3.0		D	D	D	85	85	85	85	85	85				D	D	D	85	85	85	85	85	85				
5.0		D	D	D	85	85	85	85	85	85				D	D	D	85	85	85	85	85	85				
8.0		D	D	D	90	90	85	90	90	85				D	D	D	90	90	90	95	95	95				
12.0		D	D	D	90	90	90	95	95	95				D	D	D	90	90	90	95	95	95				
20.0		C	C	C	100	100	100							C	C	C	95	95	95							
30.0		C	C	C	100	95	95							C	C	C	100	95	95							
1.0		D	D	D	85	85	85	85	85	85				D	D	D	85	85	85	85	85	85				
1.5		D	D	D	85	85	85	85	85	85				D	D	D	85	85	85	85	85	85				
2.0		D	D	D	85	85	85	85	85	85				D	D	D	85	85	85	85	85	85				
3.0		D	D	D	85	85	85	85	85	85				D	D	D	85	85	85	85	85	85				
5.0		D	D	D	90	85	85	90	85	85				D	D	D	90	85	85	90	85	85				
8.0		C	D	D	95	90	90	95	95	95				D	D	D	90	90	90	95	95	95				
12.0		C	C	C	100	100	95							D	D	D	90	90	90	95	95	95				
20.0														C	C	C	95	95	95							
30.0														C	C	C	100	100	100							
1.0		D	D	D	90	85	85	95	90	85				D	D	D	85	85	85	85	85	85				
1.5		D	D	D	85	85	85	85	85	85				D	D	D	85	85	85	85	85	85				
2.0		D	D	D	85	85	85	90	85	85				D	D	D	85	85	85	85	85	85				
3.0		D	D	D	90	90	85	95	95	85				D	D	D	85	85	85	85	85	85				
5.0		C	C	D	95	95	90			95				D	D	D	90	90	90	95	90	90				
8.0		C	C	C	100	100	100							D	D	D	90	90	90	95	95	95				
12.0														C	C	C	95	95	95							
20.0														C	C	C	95	95	95							
30.0														C	C	C	100	100	100							
1.0		C	D	D	95	90	90			95				D	D	D	85	85	85	90	90	85				
1.5		D	D	D	90	90	85	95	95	90				D	D	D	85	85	85	85	85	85				
2.0		C	D	D	95	90	90			95	90			D	D	D	85	85	85	85	85	85				
3.0		C	C	D	95	95	90			95				D	D	D	90	85	85	90	90	85				
5.0			C			100								D	D	D	90	90	90	95	95	95				
8.0														C	C	D	95	95	90		95	95				
12.0														C	C	C	95	95	95							
20.0														C	C	C	100	100	100							
30.0														C	C		100	100								

- 01
- 02
- 03
- 04
- 05
- 06
- 07
- 08
- 09
- 10
- app.

Table B-5 Installation Type 1, DN ≥ 300. Traffic Load – Ground Water below Pipe Invert
 Minimum Backfill Compaction, % Standard Proctor Density. (D = Dumped, C = Compacted)

01
02
03
04
05
06
07
08
09
10
app.

Type 1 DN ≥ 300		No Traffic Load – 1 bar Internal Vacuum – Ground Water Below Pipe Invert																																			
		Standard Trench, Bd/D = 1.8												Wide Trench, Bd/D = 3.0												<= Native Soil											
Backfill		SC1			SC2			SC3			SC4			SC1			SC2			SC3			SC4														
Pipe SN	Burial Depth, m	2500	5000	10000	2500	5000	10000	2500	5000	10000	2500	5000	10000	2500	5000	10000	2500	5000	10000	2500	5000	10000	2500	5000	10000		2500	5000	10000								
		Group 1																																			
1.0		D	D	D	85	85	85	85	85	85	90	90	90	D	D	D	85	85	85	85	85	85	95	90	90	D	D	D	85	85	85	85	85	85	95	90	90
1.5		D	D	D	85	85	85	85	85	85	90	90	90	D	D	D	85	85	85	85	85	85	95	90	90	D	D	D	85	85	85	85	85	85	95	90	90
2.0		D	D	D	85	85	85	85	85	85	90	90	90	D	D	D	85	85	85	85	85	85	95	90	90	D	D	D	85	85	85	85	85	85	95	90	90
3.0		D	D	D	85	85	85	85	85	85	95	90	90	D	D	D	85	85	85	85	85	85	95	95	90	D	D	D	85	85	85	85	85	85	95	95	90
5.0		D	D	D	85	85	85	85	85	85	95	90	90	D	D	D	90	85	85	85	85	85	90	85	85	D	D	D	90	85	85	85	85	85	95	95	90
8.0		D	D	D	90	85	85	90	85	85	95	95	95	D	D	D	90	90	90	95	90	90	95	95	95	D	D	D	90	90	90	95	90	90	95	95	95
12.0		D	D	D	90	90	85	95	90	85		95	D	D	D	90	90	90	95	95	95				D	D	D	90	90	90	95	95	95				
20.0		C	D	D	95	90	90		95	95			C	D	D	95	95	95							C	D	D	95	95	95							
30.0		C	C	C	100	95	95						C	C	C	100	95	95							C	C	C	100	95	95							
		Group 2																																			
1.0		D	D	D	85	85	85	85	85	85	90	90	90	D	D	D	85	85	85	85	85	85	95	90	90	D	D	D	85	85	85	85	85	85	95	90	90
1.5		D	D	D	85	85	85	85	85	85	90	90	90	D	D	D	85	85	85	85	85	85	95	90	90	D	D	D	85	85	85	85	85	85	95	90	90
2.0		D	D	D	85	85	85	85	85	85	90	90	90	D	D	D	85	85	85	85	85	85	95	90	90	D	D	D	85	85	85	85	85	85	95	90	90
3.0		D	D	D	85	85	85	85	85	85	95	90	90	D	D	D	85	85	85	85	85	85	95	95	90	D	D	D	85	85	85	85	85	85	95	95	90
5.0		D	D	D	85	85	85	85	85	85	95	90	90	D	D	D	90	85	85	85	85	85	90	85	85	D	D	D	90	85	85	85	85	85	95	90	90
8.0		D	D	D	90	85	85	90	85	85		95	95	D	D	D	90	90	90	95	90	90	95	95	95	D	D	D	90	90	90	95	90	90	95	95	95
12.0		D	D	D	90	90	90	95	95	90			D	D	D	90	90	90	95	95	95				D	D	D	90	90	90	95	95	95				
20.0		C	D	D	95	90	90		95	95			C	C	C	95	95	95							C	C	C	95	95	95							
30.0			C	C	100	100							C	C	C	100	95	95							C	C	C	100	95	95							
		Group 3																																			
1.0		D	D	D	85	85	85	85	85	85	90	90	90	D	D	D	85	85	85	85	85	85	95	90	90	D	D	D	85	85	85	85	85	85	95	90	90
1.5		D	D	D	85	85	85	85	85	85	90	90	90	D	D	D	85	85	85	85	85	85	95	90	90	D	D	D	85	85	85	85	85	85	95	90	90
2.0		D	D	D	85	85	85	85	85	85	90	90	90	D	D	D	85	85	85	85	85	85	95	90	90	D	D	D	85	85	85	85	85	85	95	90	90
3.0		D	D	D	85	85	85	85	85	85	95	90	90	D	D	D	90	85	85	85	85	85	90	85	85	D	D	D	90	85	85	85	85	85	95	95	90
5.0		D	D	D	90	85	85	90	85	85	95	95	90	D	D	D	90	85	85	85	85	85	95	95	90	D	D	D	90	85	85	85	85	85	95	95	90
8.0		D	D	D	90	90	85	95	90	85		95	95	D	D	D	90	90	90	95	95	95				D	D	D	90	90	90	95	95	95			
12.0		C	D	D	95	90	90		95	95			C	D	D	95	90	90		95	95				C	D	D	95	90	90		95	95				
20.0			C	C	100	100							C	C	C	95	95	95							C	C	C	95	95	95							
30.0													C	C	C	100	100	95							C	C	C	100	100	95							
		Group 4																																			
1.0		D	D	D	85	85	85	85	85	85	95	90	90	D	D	D	85	85	85	85	85	85	90	85	85	D	D	D	85	85	85	85	85	85	95	90	90
1.5		D	D	D	85	85	85	85	85	85	95	90	90	D	D	D	85	85	85	85	85	85	95	90	90	D	D	D	85	85	85	85	85	85	95	95	90
2.0		D	D	D	85	85	85	85	85	85	95	90	90	D	D	D	85	85	85	85	85	85	95	90	90	D	D	D	85	85	85	85	85	85	95	95	90
3.0		D	D	D	90	85	85	90	85	85	95	90	90	D	D	D	90	85	85	85	85	85	90	85	85	D	D	D	90	85	85	85	85	85	95	95	90
5.0		D	D	D	90	90	85	95	90	85		95	90	D	D	D	90	90	85	85	85	85	95	90	85	D	D	D	90	90	85	85	85	85	95	95	95
8.0		C	D	D	95	90	90		95	95			D	D	D	90	90	90	95	95	95				D	D	D	90	90	90	95	95	95				
12.0			C	C	100	95							C	D	D	95	90	90		95	95				C	D	D	95	90	90		95	95				
20.0													C	C	C	100	95	95							C	C	C	100	95	95							
30.0													C	C	C	100	100								C	C	C	100	100								
		Group 5																																			
1.0		D	D	D	90	90	85	95	90	85		90	D	D	D	90	85	85	85	85	85	90	85	85	D	D	D	90	85	85	85	85	85	95	95	90	
1.5		C	D	D	95	90	85	95	95	85		95	D	D	D	90	85	85	85	85	85	90	85	85	D	D	D	90	85	85	85	85	85	95	95	90	
2.0		C	D	D	95	90	85		95	85		95	D	D	D	90	85	85	85	85	85	90	85	85	D	D	D	90	85	85	85	85	85	95	95	90	
3.0		C	D	D	95	90	90		95	90			D	D	D	90	90	85	85	85	85	95	90	85	D	D	D	90	90	85	85	85	85	95	95	95	
5.0		C	C	D	100	95	90			95			D	D	D	90	90	85	85	85	85	95	95	85	D	D	D	90	90	85	85	85	85	95	95	95	
8.0			C	C	100	100							C	D	D	95	90	90		95	95				C	D	D	95	90	90		95	95				
12.0													C	C	C	95	95	95							C	C	C	95	95	95							
20.0													C	C	C	100	95	95							C	C	C	100	95	95							
30.0													C	C	C	100	100								C	C	C	100	100								
		Group 6																																			
1.0			C	D	95	90		95					D	D	D	90	90	85	85	85	85	95	90	85	D	D	D	90	90	85	85	85	85	95	95	95	
1.5			C	D	95	90		95					D	D	D	90	90	85	85	85	85	95	90	85	D	D	D	90	90	85	85	85	85	95	95	95	
2.0			C	C	95	95		95					D	D	D	90	90	85	85	85	85	95	90	85	D	D	D	90	90	85	85	85	85	95	95	95	
3.0			C	C	100	95							D	D	D	90	90	85	85	85	85	95	95	85	D	D	D	90	90	85	85	85	85	95	95	95	
5.0				C	100								C	D	D	95	90	90		95	95				C	D	D	95	90	90		95	95	95			
8.0													C	D	D	95	90	90		95	95				C	D	D	95	90	90		95	95	95			

Type 1 DN ≥ 300		No Traffic Load – No Internal Vacuum – Ground Water To Level																																				
		Standard Trench, Bd/D = 1.8												Wide Trench, Bd/D = 3.0												≤ Native Soil												
Backfill		SC1			SC2			SC3			SC4			SC1			SC2			SC3			SC4															
Pipe SN	Burial Depth, m	2500	5000	10000	2500	5000	10000	2500	5000	10000	2500	5000	10000	2500	5000	10000	2500	5000	10000	2500	5000	10000	2500	5000	10000		2500	5000	10000									
		2500	5000	10000	2500	5000	10000	2500	5000	10000	2500	5000	10000	2500	5000	10000	2500	5000	10000	2500	5000	10000	2500	5000	10000		2500	5000	10000									
		Group 1																																				
1.0		D	D	D	85	85	85	85	85	85	95	95	95	D	D	D	85	85	85	85	85	85	95	95	95	D	D	D	85	85	85	85	85	85	95	95	95	
1.5		D	D	D	85	85	85	85	85	85	95	95	95	D	D	D	85	85	85	85	85	85	95	95	95	D	D	D	85	85	85	85	85	85	95	95	95	
2.0		D	D	D	85	85	85	85	85	85	95	95	95	D	D	D	85	85	85	85	85	85	95	95	95	D	D	D	85	85	85	85	85	85	95	95	95	
3.0		D	D	D	85	85	85	85	85	85		95	95	D	D	D	85	85	85	85	85	85		95	95	D	D	D	85	85	85	85	85	85		95	95	
5.0		D	D	D	85	85	85	85	85	85				D	D	D	90	90	85	95	95	85				D	D	D	90	90	85	95	95	85				
8.0		D	D	D	90	90	90	95	95	95				D	D	D	90	90	90	95	95	95				D	D	D	90	90	90	95	95	95				
12.0		D	D	D	90	90	90	95	95	95				D	D	D	90	90	90							D	D	D	90	90	90							
20.0		C	D	D	95	90	90							C	C	C	95	95	95							C	C	C	95	95	95							
30.0		C	C	C	100	95	95							C	C	C	100	95	95							C	C	C	100	95	95							
		Group 2																																				
1.0		D	D	D	85	85	85	85	85	85	95	95	95	D	D	D	85	85	85	85	85	85	95	95	95	D	D	D	85	85	85	85	85	85	95	95	95	
1.5		D	D	D	85	85	85	85	85	85	95	95	95	D	D	D	85	85	85	85	85	85	95	95	95	D	D	D	85	85	85	85	85	85	95	95	95	
2.0		D	D	D	85	85	85	85	85	85	95	95	95	D	D	D	85	85	85	85	85	85	95	95	95	D	D	D	85	85	85	85	85	85	95	95	95	
3.0		D	D	D	85	85	85	85	85	85		95	95	D	D	D	85	85	85	85	85	85		95	95	D	D	D	85	85	85	85	85	85		95	95	
5.0		D	D	D	85	85	85	85	85	85				D	D	D	90	90	85	95	95	85				D	D	D	90	90	85	95	95	85				
8.0		D	D	D	90	90	90	95	95	95				D	D	D	90	90	90	95	95	95				D	D	D	90	90	90	95	95	95				
12.0		D	D	D	90	90	90	95	95	95				D	D	D	90	90	90							D	D	D	90	90	90							
20.0		C	C	C	95	95	95							C	C	C	95	95	95							C	C	C	95	95	95							
30.0		C	C	C	100	100								C	C	C	100	95	95							C	C	C	100	95	95							
		Group 3																																				
1.0		D	D	D	85	85	85	85	85	85	95	95	95	D	D	D	85	85	85	85	85	85	95	95	95	D	D	D	85	85	85	85	85	85	95	95	95	
1.5		D	D	D	85	85	85	85	85	85	95	95	95	D	D	D	85	85	85	85	85	85	95	95	95	D	D	D	85	85	85	85	85	85	95	95	95	
2.0		D	D	D	85	85	85	85	85	85	95	95	95	D	D	D	85	85	85	85	85	85	95	95	95	D	D	D	85	85	85	85	85	85	95	95	95	
3.0		D	D	D	85	85	85	85	85	85		95	95	D	D	D	85	85	85	85	85	85		95	95	D	D	D	85	85	85	85	85	85		95	95	
5.0		D	D	D	85	85	85	85	85	85				D	D	D	90	90	85	95	95	85				D	D	D	90	90	85	95	95	85				
8.0		D	D	D	90	90	90	95	95	95				D	D	D	90	90	90	95	95	95				D	D	D	90	90	90	95	95	95				
12.0		D	D	D	95	90	90							D	D	D	95	90	90							D	D	D	95	90	90							
20.0		C	C	C	100	100								C	C	C	95	95	95							C	C	C	95	95	95							
30.0		C	C	C	100	100	100							C	C	C	100	100	100							C	C	C	100	100	100							
		Group 4																																				
1.0		D	D	D	85	85	85	85	85	85	95	95	95	D	D	D	85	85	85	85	85	85	95	95	95	D	D	D	85	85	85	85	85	85	95	95	95	
1.5		D	D	D	85	85	85	85	85	85	95	95	95	D	D	D	85	85	85	85	85	85	95	95	95	D	D	D	85	85	85	85	85	85	95	95	95	
2.0		D	D	D	85	85	85	85	85	85	95	95	95	D	D	D	85	85	85	85	85	85	95	95	95	D	D	D	85	85	85	85	85	85	95	95	95	
3.0		D	D	D	85	85	85	85	85	85		95	95	D	D	D	85	85	85	85	85	85		95	95	D	D	D	85	85	85	85	85	85		95	95	
5.0		D	D	D	90	90	85	95	95	85				D	D	D	90	90	90	95	95	95				D	D	D	90	90	90	95	95	95				
8.0		C	D	D	95	95	90							D	D	D	90	90	90			95				D	D	D	90	90	90			95				
12.0		C	C	C	100	100	100							C	D	D	95	95	95							C	D	D	95	95	95							
20.0		C	C	C	100	95	95							C	C	C	100	95	95							C	C	C	100	95	95							
30.0		C	C	C	100	100	100							C	C	C	100	100	100							C	C	C	100	100	100							
		Group 5																																				
1.0		D	D	D	85	85	85	85	85	85	95	95	95	D	D	D	85	85	85	85	85	85	95	95	95	D	D	D	85	85	85	85	85	85	95	95	95	
1.5		D	D	D	85	85	85	85	85	85	95	95	95	D	D	D	85	85	85	85	85	85	95	95	95	D	D	D	85	85	85	85	85	85	95	95	95	
2.0		D	D	D	85	85	85	85	85	85		95	95	D	D	D	85	85	85	85	85	85		95	95	D	D	D	85	85	85	85	85	85		95	95	
3.0		D	D	D	90	90	85	95	95	85				D	D	D	85	85	85	85	85	85				D	D	D	85	85	85	85	85	85				
5.0		C	C	D	95	95	95							D	D	D	90	90	90	95	95	95				D	D	D	90	90	90	95	95	95				
8.0		C	C	D	95	95	95							D	D	D	95	90	90							D	D	D	95	90	90							
12.0		C	C	C	100	100	100							C	C	C	95	95	95							C	C	C	95	95	95							
20.0		C	C	C	100	100	100							C	C	C	100	100	100							C	C	C	100	100	100							
30.0		C	C	C	100	100	100							C	C	C	100	100	100							C	C	C	100	100	100							
		Group 6																																				
1.0		D	D	D	85	85	85	90	85	85		95	95	D	D	D	85	85	85	85	85	85	95	95	95	D	D	D	85	85	85	85	85	85	95	95	95	
1.5		D	D	D	90	85	85	95	85	85			95	D	D	D	85	85	85	85	85	85			95	D	D	D	85	85	85	85	85	85			95	95
2.0		D	D	D	90	90	85		95	85			95	D	D	D	85	85	85	85	85	85			95	D	D	D	85	85	85	85	85	85			95	95
3.0		C	C	D	95	95	90							D	D	D	90	90	85	95	95	85				D	D	D	90	90	85	95	95	85				
5.0		C	C	D	95	95	95							D	D	D	90	90	90	95	95	95				D	D	D	90	90	90	95	95	95				
8.0		C	C	D	95	95	95							D	D	D																						

01
02
03
04
05
06
07
08
09
10
app.

Type 1 DN ≥ 300		Traffic Load AASHTO HS 20 – No Internal Vacuum – Ground Water To Level																								
		Standard Trench, Bd/D = 1.8												Wide Trench, Bd/D = 3.0												<= Native Soil
Backfill		SC1			SC2			SC3			SC4			SC1			SC2			SC3			SC4			
Pipe SN	Burial Depth, m	2500	5000	10000	2500	5000	10000	2500	5000	10000	2500	5000	10000	2500	5000	10000	2500	5000	10000	2500	5000	10000	2500	5000	10000	
		Group 1																								
1.0		D	D	D	85	85	85	90	85	85				D	D	D	85	85	85	90	90	85				
1.5		D	D	D	85	85	85	85	85	85				D	D	D	85	85	85	85	85	85				
2.0		D	D	D	85	85	85	85	85	85				D	D	D	85	85	85	85	85	85				
3.0		D	D	D	85	85	85	85	85	85				D	D	D	85	85	85	85	85	85				
5.0		D	D	D	85	85	85	85	85	85				D	D	D	90	90	85	95	95	85				
8.0		D	D	D	90	90	90	95	95	95				D	D	D	90	90	90	95	95	95				
12.0		D	D	D	90	90	90	95	95	95				D	D	D	90	90	90							
20.0		C	D	D	95	90	90							C	C	C	95	95	95							
30.0		C	C	C	100	95	95							C	C	C	100	95	95							
		Group 2																								
1.0		D	D	D	85	85	85	90	85	85				D	D	D	85	85	85	90	90	85				
1.5		D	D	D	85	85	85	85	85	85				D	D	D	85	85	85	85	85	85				
2.0		D	D	D	85	85	85	85	85	85				D	D	D	85	85	85	85	85	85				
3.0		D	D	D	85	85	85	85	85	85				D	D	D	85	85	85	85	85	85				
5.0		D	D	D	85	85	85	85	85	85				D	D	D	90	90	85	95	95	85				
8.0		D	D	D	90	90	90	95	95	95				D	D	D	90	90	90	95	95	95				
12.0		D	D	D	90	90	90	95	95	95				D	D	D	90	90	90							
20.0		C	C	C	95	95	95							C	C	C	95	95	95							
30.0			C	C	100	100								C	C	C	100	95	95							
		Group 3																								
1.0		D	D	D	85	85	85	90	85	85				D	D	D	85	85	85	90	90	85				
1.5		D	D	D	85	85	85	85	85	85				D	D	D	85	85	85	85	85	85				
2.0		D	D	D	85	85	85	85	85	85				D	D	D	85	85	85	85	85	85				
3.0		D	D	D	85	85	85	85	85	85				D	D	D	85	85	85	85	85	85				
5.0		D	D	D	85	85	85	85	85	85				D	D	D	90	90	85	95	95	85				
8.0		D	D	D	90	90	90	95	95	95				D	D	D	90	90	90			95				
12.0		D	D	D	95	95	90							D	D	D	95	90	90							
20.0			C	C	100	100								C	C	C	95	95	95							
30.0														C	C	C	100	100	100							
		Group 4																								
1.0		D	D	D	85	85	85	90	85	85				D	D	D	85	85	85	90	90	85				
1.5		D	D	D	85	85	85	85	85	85				D	D	D	85	85	85	85	85	85				
2.0		D	D	D	85	85	85	85	85	85				D	D	D	85	85	85	85	85	85				
3.0		D	D	D	85	85	85	85	85	85				D	D	D	85	85	85	85	85	85				
5.0		D	D	D	90	90	85	95	95	85				D	D	D	90	90	90	95	95	95				
8.0		C	D	D	95	95	90							D	D	D	90	90	90							
12.0		C	C	C	100	100	100							C	D	D	95	95	95							
20.0														C	C	C	100	95	95							
30.0															C	C	100	100								
		Group 5																								
1.0		D	D	D	90	85	85		95	90				D	D	D	85	85	85	95	90	90				
1.5		D	D	D	90	85	85	95	85	85				D	D	D	85	85	85	85	85	85				
2.0		D	D	D	90	85	85	95	85	85				D	D	D	85	85	85	85	85	85				
3.0		D	D	D	90	90	85		95	85				D	D	D	90	85	85	95	85	85				
5.0		C	C	D	95	95	95							D	D	D	90	90	90	95	95	95				
8.0				C		100								D	D	D	95	90	90							
12.0														C	C	C	95	95	95							
20.0														C	C	C	100	100	100							
30.0															C	C	100	100								
		Group 6																								
1.0		C	D	D	95	95	90							D	D	D	90	90	85	95	95	90				
1.5		C	D	D	95	90	90		95					D	D	D	90	85	85	95	85	85				
2.0		C	D	D	95	95	90		95					D	D	D	90	85	85	95	95	85				
3.0		C	C	D	95	95	95							D	D	D	90	90	85	95	95	85				
5.0				C		100								D	D	D	90	90	90			95				
8.0														C	C	D	95	95	95							
12.0														C	C	C	95	95	95							
20.0															C	C	100	100								
30.0																C	C	100	100							

Table B-8 Installation Type 1, DN ≥ 300. Traffic Load – Ground Water to Level
Minimum Backfill Compaction, % Standard Proctor Density. (D = Dumped, C = Compacted)

Type 1 DN ≥ 300		No Traffic Load – 1.0 bar Internal Vacuum – Ground Water To Level																				<= Native Soil			
Backfill	Pipe SN	Standard Trench, Bd/D = 1.8												Wide Trench, Bd/D = 3.0											
		SC1			SC2			SC3			SC4			SC1			SC2			SC3			SC4		
Burial Depth, m		2500	5000	10000	2500	5000	10000	2500	5000	10000	2500	5000	10000	2500	5000	10000	2500	5000	10000	2500	5000	10000	2500	5000	10000
1.0		D	D	D	85	85	85	90	85	85				95	D	D	D	90	85	85	95	90	85		
1.5		D	D	D	85	85	85	85	85	85				95	D	D	D	90	85	85	95	85	85		
2.0		D	D	D	85	85	85	85	85	85				95	D	D	D	90	85	85	95	85	85		
3.0		D	D	D	90	85	85	95	85	85					D	D	D	90	90	85	95	95	85		
5.0		D	D	D	90	85	85	95	85	85					D	D	D	90	90	85	95	95	85		
8.0		D	D	D	90	90	90	95	95	95					D	D	D	90	90	90		95	95		
12.0		D	D	D	90	90	90		95	95					C	D	D	95	90	90					
20.0		C	C	D	100	95	90								C	C	C	100	95	95					
30.0			C	C		100	95								C	C	C	100	100	95					
1.0		D	D	D	85	85	85	90	85	85				95	D	D	D	90	85	85	95	90	85		
1.5		D	D	D	85	85	85	85	85	85				95	D	D	D	90	85	85	95	85	85		
2.0		D	D	D	85	85	85	85	85	85				95	D	D	D	90	85	85	95	85	85		
3.0		D	D	D	90	85	85	95	85	85					D	D	D	90	90	85	95	95	85		
5.0		D	D	D	90	85	85	95	85	85					D	D	D	90	90	85	95	95	85		
8.0		D	D	D	90	90	90		95	95					D	D	D	95	90	90			95		
12.0		C	D	D	95	90	90			95					C	D	D	95	95	90					
20.0			C	C		95	95								C	C	C	100	95	95					
30.0				C		100										C	C		100	95					
1.0		D	D	D	85	85	85	90	85	85				95	D	D	D	90	85	85	95	90	85		
1.5		D	D	D	85	85	85	85	85	85				95	D	D	D	90	85	85	95	85	85		
2.0		D	D	D	85	85	85	85	85	85				95	D	D	D	90	85	85	95	85	85		
3.0		D	D	D	90	85	85	95	85	85					D	D	D	90	90	85	95	95	85		
5.0		D	D	D	90	90	85	95	95	85					D	D	D	90	90	90		95	95		
8.0		D	D	D	95	90	90		95	95					D	D	D	95	90	90			95		
12.0		C	C	D	100	95	90								C	D	D	95	95	90					
20.0				C			100								C	C	C	100	95	95					
30.0																C	C		100	100					
1.0		D	D	D	85	85	85	95	90	85				95	D	D	D	90	85	85	95	90	90		
1.5		D	D	D	90	85	85	95	85	85				95	D	D	D	90	85	85	95	85	85		
2.0		D	D	D	90	85	85	95	85	85				95	D	D	D	90	90	85	95	95	85		
3.0		D	D	D	90	90	85	95	95	85					D	D	D	90	90	85	95	95	85		
5.0		C	D	D	95	90	90		95	95					D	D	D	90	90	90		95	95		
8.0			C	D		95	90								C	D	D	95	90	90			95		
12.0				C			100	100							C	C	D	95	95	95					
20.0															C	C	C	100	100	95					
30.0																C	C		100	100					
1.0		C	D	D	95	90	85		95	90					D	D	D	90	90	85	95	95	90		
1.5		C	D	D	95	90	90			95					D	D	D	90	90	85	95	95	85		
2.0		C	D	D	95	90	90			95					D	D	D	90	90	85	95	95	85		
3.0		C	C	D	100	95	90								D	D	D	90	90	90		95	95		
5.0			C	C		100	95								D	D	D	95	90	90			95		
8.0				C			100								C	D	D	95	95	90					
12.0															C	C	C	100	95	95					
20.0																C	C		100	100					
30.0																	C			100					
1.0			C	D		95	95								D	D	D	90	90	85		95	95		
1.5				C	C		100	95							D	D	D	90	90	90		95	95		
2.0					C	C		100	95						D	D	D	90	90	90		95	95		
3.0						C			95						D	D	D	95	90	90			95		
5.0															C	D	D	95	90	90					
8.0															C	C	D	100	95	95					
12.0															C	C	C	100	100	95					
20.0																	C			100					
30.0																		C			100				

- 01
- 02
- 03
- 04
- 05
- 06
- 07
- 08
- 09
- 10
- app.

Table B-9 Installation Type 1, DN ≥ 300. Vacuum 1.0 bar – Ground Water to Level
 Minimum Backfill Compaction, % Standard Proctor Density. (D = Dumped, C = Compacted)

01
02
03
04
05
06
07
08
09
10
app.

Type 1 DN ≤ 250	No Traffic Load No Internal Vacuum Ground Water Below								Traffic, AASHTO HS 20 No Internal Vacuum Ground Water Below								No Traffic Load 1 bar Internal Vacuum Ground Water Below								<= Native Soil								
	Bd/D = 1.8				Bd/D = 3.0				Bd/D = 1.8				Bd/D = 3.0				Bd/D = 1.8				Bd/D = 3.0												
	Backfill				Backfill				Backfill				Backfill				Backfill				Backfill												
Trench	1	2	3	4	1	2	3	4	1	2	3	4	1	2	3	4	1	2	3	4	1	2	3	4	1	2	3	4	1	2	3	4	Group 1
Backfill	1				2				3				4				1				2				3				4				
Pipe SN	10000				10000				10000				10000				10000				10000				10000				10000				
Burial Depth, m	10000				10000				10000				10000				10000				10000				10000				10000				
1.0	D	85	85	90	D	85	85	90	D	85	85		D	85	85		D	85	85	90	D	85	85	90	D	85	85	90					
1.5	D	85	85	90	D	85	85	90	D	85	85		D	85	85		D	85	85	90	D	85	85	90	D	85	85	90					
2.0	D	85	85	90	D	85	85	90	D	85	85		D	85	85		D	85	85	90	D	85	85	90	D	85	85	90					
3.0	D	85	85	90	D	85	85	90	D	85	85		D	85	85		D	85	85	90	D	85	85	90	D	85	85	90					
5.0	D	85	85	90	D	85	85	95	D	85	85		D	85	85		D	85	85	90	D	85	85	90	D	85	85	95					
8.0	D	85	85	95	D	90	95		D	85	85		D	90	95		D	85	85	95	D	90	95		D	90	95						
12.0	D	90	95		D	90	95		D	90	95		D	90	95		D	90	95		D	90	95		D	90	95						
20.0	D	90	95		C	95			D	90	95		C	95			D	90	95		D	90	95		C	95							
30.0	C	95			C	95			C	95			C	95			C	95			C	95			C	95							
1.0	D	85	85	90	D	85	85	90	D	85	85		D	85	85		D	85	85	90	D	85	85	90	D	85	85	90					
1.5	D	85	85	90	D	85	85	90	D	85	85		D	85	85		D	85	85	90	D	85	85	90	D	85	85	90					
2.0	D	85	85	90	D	85	85	90	D	85	85		D	85	85		D	85	85	90	D	85	85	90	D	85	85	90					
3.0	D	85	85	90	D	85	85	90	D	85	85		D	85	85		D	85	85	90	D	85	85	90	D	85	85	90					
5.0	D	85	85	90	D	85	85	95	D	85	85		D	85	85		D	85	85	90	D	85	85	90	D	85	85	95					
8.0	D	85	85	95	D	90	95		D	85	85		D	90	95		D	85	85	95	D	90	95		D	90	95						
12.0	D	90	95		D	90	95		D	90	95		D	90	95		D	90	95		D	90	95		D	90	95						
20.0	C	95			C	95			C	95			C	95			C	95			C	95			C	95							
30.0					C	100							C	100			C	100			C	100			C	100							
1.0	D	85	85	90	D	85	85	90	D	85	85		D	85	85		D	85	85	90	D	85	85	90	D	85	85	90					
1.5	D	85	85	90	D	85	85	90	D	85	85		D	85	85		D	85	85	90	D	85	85	90	D	85	85	90					
2.0	D	85	85	90	D	85	85	90	D	85	85		D	85	85		D	85	85	90	D	85	85	90	D	85	85	90					
3.0	D	85	85	90	D	85	85	90	D	85	85		D	85	85		D	85	85	90	D	85	85	90	D	85	85	90					
5.0	D	85	85	90	D	85	85	95	D	85	85		D	85	85		D	85	85	90	D	85	85	90	D	85	85	95					
8.0	D	90	95		D	90	95		D	90	95		D	90	95		D	90	95		D	90	95		D	90	95						
12.0	C	95			D	90	95		C	95			D	90	95		C	95			D	90	95		C	95							
20.0	C	100			C	95			C	100			C	95			C	95			C	100			C	95							
30.0					C	100							C	100			C	100			C	100			C	100							
1.0	D	85	85	90	D	85	85	90	D	85	85		D	85	85		D	85	85	90	D	85	85	90	D	85	85	90					
1.5	D	85	85	90	D	85	85	90	D	85	85		D	85	85		D	85	85	90	D	85	85	90	D	85	85	90					
2.0	D	85	85	90	D	85	85	90	D	85	85		D	85	85		D	85	85	90	D	85	85	90	D	85	85	90					
3.0	D	85	85	90	D	85	85	90	D	85	85		D	85	85		D	85	85	90	D	85	85	90	D	85	85	90					
5.0	D	90	90	95	D	90	90	95	D	90	90		D	90	90		D	90	90	95	D	90	90	95	D	90	90	95					
8.0	C	95			D	90	95		C	95			D	90	95		C	95			D	90	95		C	95							
12.0					C	95							C	95			C	95			C	95			C	95							
20.0					C	100							C	100			C	100			C	100			C	100							
30.0					C	100							C	100			C	100			C	100			C	100							
1.0	D	85	85	90	D	85	85	90	D	90			D	85	90		D	90	95		D	90	95		D	85	85	95					
1.5	D	85	85	90	D	85	85	90	D	90	95		D	85	85		D	90	95		D	90	95		D	85	85	95					
2.0	D	85	85	95	D	85	85	90	D	90	95		D	85	85		D	90	95		C	95	95		D	85	85	95					
3.0	C	95			D	85	85	95	C	95			D	90	90		D	90	90		C	95			D	85	85	95					
5.0					D	90	95						D	90	95		D	90	95						D	90	95						
8.0					C	95							C	95			C	95			C	95			C	95							
12.0					C	95							C	95			C	95			C	95			C	95							
20.0					C	100							C	100			C	100			C	100			C	100							
30.0					C	100							C	100			C	100			C	100			C	100							
1.0	D	85	85	90	D	85	85	90	D	90			D	85	90		D	90	95		D	90	95		D	85	85	95					
1.5	D	85	85	90	D	85	85	90	D	90	95		D	85	85		D	90	95		D	90	95		D	85	85	95					
2.0	D	85	85	95	D	85	85	90	D	90	95		D	85	85		D	90	95		C	95	95		D	85	85	95					
3.0	C	95			D	85	85	95	C	95			D	90	90		D	90	90		C	95			D	85	85	95					
5.0					D	90	95						D	90	95		D	90	95						D	90	95						
8.0					C	95							C	95			C	95			C	95			C	95							
12.0					C	95							C	95			C	95			C	95			C	95							
20.0					C	100							C	100			C	100			C	100			C	100							
30.0					C	100							C	100			C	100			C	100			C	100							
1.0	D	85	85	90	D	85	85	90	D	90			D	85	90		D	90	95		D	90	95		D	85	85	95					
1.5	D	85	85	90	D	85	85	90	D	90	95		D	85	85		D	90	95		D	90	95		D	85	85	95					
2.0	D	85	85	95	D	85	85	90	D	90	95		D	85	85		D	90	95		C	95	95		D	85	85	95					
3.0	C	95			D	85	85	95	C	95			D	90	90		D	90	90		C	95			D	85	85	95					
5.0					D	90	95						D	90	95		D	90	95						D	90	95						
8.0					C	95							C	95			C	95			C	95			C	95							
12.0					C	95							C	95			C	95			C	95			C	95							
20.0					C	100							C	100			C	100			C	100			C	100							
30.0					C	100							C	100			C	100			C	100			C	100							

Table B-10 Installation Type 1, DN ≤ 250. Ground Water Below Pipe Invert
Minimum Backfill Compaction, % Standard Proctor Density. (D = Dumped, C = Compacted)

Type 1 DN ≤ 250	No Traffic Load No Internal Vacuum Ground Water To Level								Traffic, AASHTO HS 20 No Internal Vacuum Ground Water To Level								No Traffic Load 1 bar Internal Vacuum Ground Water To Level								<= Native Soil								
	Bd/D = 1.8				Bd/D = 3.0				Bd/D = 1.8				Bd/D = 3.0				Bd/D = 1.8				Bd/D = 3.0												
	Trench		Backfill		Trench		Backfill		Trench		Backfill		Trench		Backfill		Trench		Backfill		Trench		Backfill										
Pipe SN	1	2	3	4	1	2	3	4	1	2	3	4	1	2	3	4	1	2	3	4	1	2	3	4	1	2	3	4	1	2	3	4	
Burial Depth, m	10000	10000	10000	10000	10000	10000	10000	10000	10000	10000	10000	10000	10000	10000	10000	10000	10000	10000	10000	10000	10000	10000	10000	10000	10000	10000	10000	10000					
1.0	D	85	85	95	D	85	85	95	D	85	85		D	85	90		D	85	85	95	D	85	85		D	85	85						
1.5	D	85	85	95	D	85	85	95	D	85	85		D	85	85		D	85	85	95	D	85	85		D	85	85						
2.0	D	85	85	95	D	85	85	95	D	85	85		D	85	85		D	85	85	95	D	85	85		D	85	85						
3.0	D	85	85	95	D	85	85		D	85	85		D	85	85		D	85	85		D	85	85		D	85	85						
5.0	D	85	85		D	90	95		D	85	85		D	90	95		D	85	85		D	85	85		D	90	95						
8.0	D	90	95		D	90	95		D	90	95		D	90	95		D	90	95		D	90	95		D	90	95						
12.0	D	90			D	90			D	90			D	90			D	90			D	90			D	90							
20.0	C	95			C	95			C	95			C	95			C	95			C	95			C	95							
30.0	C	100			C	100			C	100			C	100			C	100			C	100			C	100							
1.0	D	85	85	95	D	85	85	95	D	85	85		D	85	90		D	85	85	95	D	85	85		D	85	85						
1.5	D	85	85	95	D	85	85	95	D	85	85		D	85	85		D	85	85	95	D	85	85		D	85	85						
2.0	D	85	85	95	D	85	85	95	D	85	85		D	85	85		D	85	85	95	D	85	85		D	85	85						
3.0	D	85	85	95	D	85	85		D	85	85		D	85	85		D	85	85		D	85	85		D	85	85						
5.0	D	85	85		D	90	95		D	85	85		D	90	95		D	85	85		D	85	85		D	90	95						
8.0	D	90	95		D	90			D	90	95		D	90			D	90	95		D	90	95		D	90							
12.0	D	90			D	95			D	90			D	95			D	90			D	95			D	95							
20.0	C	95			C	95			C	95			C	95			C	95			C	95			C	95							
30.0					C	100							C	100							C	100			C	100							
1.0	D	85	85	95	D	85	85	95	D	85	85		D	85	90		D	85	85	95	D	85	85		D	85	85						
1.5	D	85	85	95	D	85	85	95	D	85	85		D	85	85		D	85	85	95	D	85	85		D	85	85						
2.0	D	85	85	95	D	85	85	95	D	85	85		D	85	85		D	85	85	95	D	85	85		D	85	85						
3.0	D	85	85	95	D	85	85		D	85	85		D	85	85		D	85	85		D	85	85		D	85	85						
5.0	D	85	85		D	90	95		D	85	85		D	90	95		D	85	85		D	85	85		D	90	95						
8.0	D	90	95		D	90			D	90	95		D	90			D	90	95		D	90	95		D	90							
12.0					C	95							C	95							C	95			C	95							
20.0					C	100							C	100							C	100			C	100							
30.0					C	100							C	100							C	100			C	100							
1.0	D	85	85	95	D	85	85	95	D	85	95		D	85	90		D	85	90		D	85	90		D	85	90						
1.5	D	85	85	95	D	85	85	95	D	85	85		D	85	85		D	90	95		D	85	85		D	85	85						
2.0	D	85	85	95	D	85	85	95	D	85	85		D	85	85		D	90	95		D	85	85		D	85	85						
3.0	D	90	95		D	85	85		D	90			D	90	95		D	90			D	90			D	90	95						
5.0	C	95			D	90	95		C	95			D	90	95		C	95			C	95			D	90	95						
8.0					C	95							C	95							C	95			C	95							
12.0					C	95							C	95							C	95			C	95							
20.0					C	100							C	100							C	100			C	100							
30.0					C	100							C	100							C	100			C	100							
1.0	D	85	85	95	D	85	85	95	D	95			D	85	95		D	95			D	95			D	85	95						
1.5	D	85	85	95	D	85	85	95	D	90			D	85	85		D	85	85		C	95			D	90	95						
2.0	D	90	95		D	85	85		D	90			D	85	85		D	85	85		C	95			D	90	95						
3.0	C	95			D	90	95		C	95			D	90	95		C	95			C	95			D	90	95						
5.0					D	90							D	90											D	90							
8.0					C	95							C	95											C	95							
12.0					C	100							C	100											C	100							
20.0																																	
30.0																																	

Table B-11 Installation Type 1, DN ≤ 250. Ground Water to Level

Minimum Backfill Compaction, % Standard Proctor Density. (D = Dumped, C = Compacted)

- 01
- 02
- 03
- 04
- 05
- 06
- 07
- 08
- 09
- 10
- app.

01
02
03
04
05
06
07
08
09
10
app.

Type 2 DN ≥ 300		No Traffic Load – No Internal Vacuum – Ground Water Below Pipe Invert																								
		Standard Trench, Bd/D = 1.8												Wide Trench, Bd/D = 3.0												<= Native Soil
Upper Backfill		SC3 85% SPD						SC4 90% SPD						SC3 85% SPD						SC4 90% SPD						
Backfill		SC1			SC2			SC1			SC2			SC1			SC2			SC1			SC2			
Pipe SN Burial Depth, m		2500	5000	10000	2500	5000	10000	2500	5000	10000	2500	5000	10000	2500	5000	10000	2500	5000	10000	2500	5000	10000	2500	5000	10000	
1.0		D	D	D	85	85	85	D	D	D	85	85	85	D	D	D	85	85	85	D	D	D	85	85	85	
1.5		D	D	D	85	85	85	D	D	D	85	85	85	D	D	D	85	85	85	D	D	D	85	85	85	
2.0		D	D	D	85	85	85	D	D	D	85	85	85	D	D	D	85	85	85	D	D	D	85	85	85	
3.0		D	D	D	85	85	85	D	D	D	85	85	85	D	D	D	85	85	85	D	D	D	85	85	85	
5.0		D	D	D	85	85	85	D	D	D	85	85	85	D	D	D	85	85	85	D	D	D	85	85	85	
8.0		D	D	D	85	85	85	D	D	D	85	85	85	D	D	D	85	85	85	D	D	D	85	85	85	
12.0		D	D	D	90	90	85							D												
20.0			D	D			90	90																		
1.0		D	D	D	85	85	85	D	D	D	85	85	85	D	D	D	85	85	85	D	D	D	85	85	85	
1.5		D	D	D	85	85	85	D	D	D	85	85	85	D	D	D	85	85	85	D	D	D	85	85	85	
2.0		D	D	D	85	85	85	D	D	D	85	85	85	D	D	D	85	85	85	D	D	D	85	85	85	
3.0		D	D	D	85	85	85	D	D	D	85	85	85	D	D	D	85	85	85	D	D	D	85	85	85	
5.0		D	D	D	85	85	85	D	D	D	85	85	85	D	D	D	85	85	85	D	D	D	85	85	85	
8.0		D	D	D	85	85	85	D	D	D	85	85	85	D	D	D	90	90	90				90	90	90	
12.0		D	D	D	90	90	90							D	D		90	90								
20.0				C			95																			
1.0		D	D	D	85	85	85	D	D	D	85	85	85	D	D	D	85	85	85	D	D	D	85	85	85	
1.5		D	D	D	85	85	85	D	D	D	85	85	85	D	D	D	85	85	85	D	D	D	85	85	85	
2.0		D	D	D	85	85	85	D	D	D	85	85	85	D	D	D	85	85	85	D	D	D	85	85	85	
3.0		D	D	D	85	85	85	D	D	D	85	85	85	D	D	D	85	85	85	D	D	D	85	85	85	
5.0		D	D	D	85	85	85	D	D	D	85	85	85	D	D	D	85	85	85	D	D	D	85	85	85	
8.0		D	D	D	85	85	85	D	D	D	85	85	85	D	D	D	90	90	90				90	90	90	
12.0			D	D			90	90						D	D		90	90								
20.0																										
1.0		D	D	D	85	85	85	D	D	D	85	85	85	D	D	D	85	85	85	D	D	D	85	85	85	
1.5		D	D	D	85	85	85	D	D	D	85	85	85	D	D	D	85	85	85	D	D	D	85	85	85	
2.0		D	D	D	85	85	85	D	D	D	85	85	85	D	D	D	85	85	85	D	D	D	85	85	85	
3.0		D	D	D	85	85	85	D	D	D	85	85	85	D	D	D	85	85	85	D	D	D	85	85	85	
5.0		D	D	D	85	85	85	D	D	D	85	85	85	D	D	D	90	85	85	D	D	D	90	90	85	
8.0		C	C	D	95	95	90		C	C		95	95	D	D	D	90	90	90				D		90	
12.0				C			100																			
20.0																										
1.0		D	D	D	85	85	85	D	D	D	85	85	85	D	D	D	85	85	85	D	D	D	85	85	85	
1.5		D	D	D	85	85	85	D	D	D	85	85	85	D	D	D	85	85	85	D	D	D	85	85	85	
2.0		D	D	D	85	85	85	D	D	D	85	85	85	D	D	D	85	85	85	D	D	D	85	85	85	
3.0		D	D	D	90	90	85	D	D	D	90	90	85	D	D	D	85	85	85	D	D	D	85	85	85	
5.0		C	C	C	100	95	95		C	C		95	95	D	D	D	90	90	85	D	D	D	90	90	90	
8.0															D	D		90	90			D		90		
12.0																C		95								
20.0																										
1.0		D	D	D	85	85	85	D	D	D	85	85	85	D	D	D	85	85	85	D	D	D	85	85	85	
1.5		D	D	D	90	85	85	D	D	D	90	85	85	D	D	D	85	85	85	D	D	D	85	85	85	
2.0		D	D	D	90	90	85	D	D	D	90	90	85	D	D	D	85	85	85	D	D	D	85	85	85	
3.0		C	C	D	100	95	90		C	D		95	90	D	D	D	90	85	85	D	D	D	90	85	85	
5.0															D	D	D	90	90	90		D	D	90	90	
8.0																C		95								
12.0																										
20.0																										

Table B-12 Installation Type 2, DN ≥ 300. No Vacuum - Ground Water below Pipe Invert
Minimum Backfill Compaction, % Standard Proctor Density. (D = Dumped, C = Compacted)

Type 2 DN ≥ 300		No Traffic Load – 0.5 bar Internal Vacuum – Ground Water Below Pipe Invert																								
		Standard Trench, Bd/D = 1.8												Wide Trench, Bd/D = 3.0												
Upper Backfill		SC3 85% SPD						SC4 90% SPD						SC3 85% SPD						SC4 90% SPD						
Backfill		SC1			SC2			SC1			SC2			SC1			SC2			SC1			SC2			
Pipe SN Burial Depth, m		2500	5000	10000	2500	5000	10000	2500	5000	10000	2500	5000	10000	2500	5000	10000	2500	5000	10000	2500	5000	10000	2500	5000	10000	
		<= Native Soil																								
Group 1																										
1.0		D	D	D	85	85	85	D	D	D	85	85	85	D	D	D	85	85	85	D	D	D	85	85	85	
1.5		D	D	D	85	85	85	D	D	D	85	85	85	D	D	D	85	85	85	D	D	D	85	85	85	
2.0		D	D	D	85	85	85	D	D	D	85	85	85	D	D	D	85	85	85	D	D	D	85	85	85	
3.0		D	D	D	85	85	85	D	D	D	85	85	85	D	D	D	85	85	85	D	D	D	85	85	85	
5.0		D	D	D	85	85	85	D	D	D	85	85	85	D	D	D	85	85	85	D	D	D	85	85	85	
8.0		D	D	D	85	85	85	D	D	D	85	85	85	D	D	D	85	85	85	D	D	D	85	85	85	
12.0			D	D											D											
20.0				D																						
Group 2																										
1.0		D	D	D	85	85	85	D	D	D	85	85	85	D	D	D	85	85	85	D	D	D	85	85	85	
1.5		D	D	D	85	85	85	D	D	D	85	85	85	D	D	D	85	85	85	D	D	D	85	85	85	
2.0		D	D	D	85	85	85	D	D	D	85	85	85	D	D	D	85	85	85	D	D	D	85	85	85	
3.0		D	D	D	85	85	85	D	D	D	85	85	85	D	D	D	85	85	85	D	D	D	85	85	85	
5.0		D	D	D	85	85	85	D	D	D	85	85	85	D	D	D	85	85	85	D	D	D	85	85	85	
8.0		D	D	D	85	85	85	D	D	D	85	85	85	D	D	D	85	85	85	D	D	D	85	85	85	
12.0			D	D											D											
20.0				C																						
Group 3																										
1.0		D	D	D	85	85	85	D	D	D	85	85	85	D	D	D	85	85	85	D	D	D	85	85	85	
1.5		D	D	D	85	85	85	D	D	D	85	85	85	D	D	D	85	85	85	D	D	D	85	85	85	
2.0		D	D	D	85	85	85	D	D	D	85	85	85	D	D	D	85	85	85	D	D	D	85	85	85	
3.0		D	D	D	85	85	85	D	D	D	85	85	85	D	D	D	85	85	85	D	D	D	85	85	85	
5.0		D	D	D	85	85	85	D	D	D	85	85	85	D	D	D	85	85	85	D	D	D	85	85	85	
8.0		D	D	D	85	85	85	D	D	D	85	85	85	D	D	D	85	85	85	D	D	D	85	85	85	
12.0				D											D											
20.0																										
Group 4																										
1.0		D	D	D	85	85	85	D	D	D	85	85	85	D	D	D	85	85	85	D	D	D	85	85	85	
1.5		D	D	D	85	85	85	D	D	D	85	85	85	D	D	D	85	85	85	D	D	D	85	85	85	
2.0		D	D	D	85	85	85	D	D	D	85	85	85	D	D	D	85	85	85	D	D	D	85	85	85	
3.0		D	D	D	85	85	85	D	D	D	85	85	85	D	D	D	85	85	85	D	D	D	85	85	85	
5.0		D	D	D	85	85	85	D	D	D	85	85	85	D	D	D	85	85	85	D	D	D	85	85	85	
8.0				D											D											
12.0																										
20.0																										
Group 5																										
1.0		D	D	D	85	85	85	D	D	D	85	85	85	D	D	D	85	85	85	D	D	D	85	85	85	
1.5		D	D	D	85	85	85	D	D	D	85	85	85	D	D	D	85	85	85	D	D	D	85	85	85	
2.0		D	D	D	85	85	85	D	D	D	85	85	85	D	D	D	85	85	85	D	D	D	85	85	85	
3.0			D	D											D							D	D		85	85
5.0				C												D						D			90	
8.0																D						D			90	
12.0																										
20.0																										
Group 6																										
1.0				D											D						D				85	
1.5					D										D						D				85	
2.0						D									D						D				85	
3.0																D					D				85	
5.0																	D				D				85	
8.0																		D			D				85	
12.0																										
20.0																										

Table B-13 Installation Type 2, DN ≥ 300. 0.5 bar Vacuum - Ground Water below Pipe
 Minimum Backfill Compaction, % Standard Proctor Density. (D = Dumped, C = Compacted)

- 01
- 02
- 03
- 04
- 05
- 06
- 07
- 08
- 09
- 10
- app.

Type 2 DN ≥ 300		No Traffic Load – No Internal Vacuum – Ground Water To Level																													
		Standard Trench, Bd/D = 1.8												Wide Trench, Bd/D = 3.0																	
Upper Backfill		SC3 85% SPD						SC4 95% SPD						SC3 85% SPD						SC4 95% SPD											
Backfill		SC1			SC2			SC1			SC2			SC1			SC2			SC1			SC2								
Pipe SN Burial Depth, m		2500	5000	10000	2500	5000	10000	2500	5000	10000	2500	5000	10000	2500	5000	10000	2500	5000	10000	2500	5000	10000	2500	5000	10000						
		<= Native Soil																													
Group 1		D	D	D	85	85	85	D	D	D	85	85	85	D	D	D	85	85	85	D	D	D	85	85	85	D	D	D	85	85	85
Group 2		D	D	D	85	85	85	D	D	D	85	85	85	D	D	D	85	85	85	D	D	D	85	85	85	D	D	D	85	85	85
Group 3		D	D	D	85	85	85	D	D	D	85	85	85	D	D	D	85	85	85	D	D	D	85	85	85	D	D	D	85	85	85
Group 4		D	D	D	85	85	85	D	D	D	85	85	85	D	D	D	85	85	85	D	D	D	85	85	85	D	D	D	85	85	85
Group 5		D	D	D	85	85	85	D	D	D	85	85	85	D	D	D	85	85	85	D	D	D	85	85	85	D	D	D	85	85	85
Group 6		D	D	D	85	85	85	D	D	D	85	85	85	D	D	D	85	85	85	D	D	D	85	85	85	D	D	D	85	85	85

Table B-15 Installation Type 2, DN ≥ 300. No Vacuum - Ground Water to Level
 Minimum Backfill Compaction, % Standard Proctor Density. (D = Dumped, C = Compacted)

- 01
- 02
- 03
- 04
- 05
- 06
- 07
- 08
- 09
- 10
- app.

01
02
03
04
05
06
07
08
09
10
app.

Type 2 DN ≥ 300		No Traffic Load – 0.5 bar Internal Vacuum – Ground Water To Level																														
		Standard Trench, Bd/D = 1.8												Wide Trench, Bd/D = 3.0												<= Native Soil						
Upper Backfill		SC3 85% SPD						SC4 95% SPD						SC3 85% SPD						SC4 95% SPD												
Backfill		SC1			SC2			SC1			SC2			SC1			SC2			SC1			SC2									
Pipe SN Burial Depth, m		2500	5000	10000	2500	5000	10000	2500	5000	10000	2500	5000	10000	2500	5000	10000	2500	5000	10000	2500	5000	10000	2500	5000	10000							
1.0		D	D	D	85	85	85	D	D	D	85	85	85	D	D	D	85	85	85	D	D	D	85	85	85	D	D		85	85		
1.5		D	D	D	85	85	85	D	D	D	85	85	85	D	D	D	85	85	85	D	D	D	85	85	85	D	D		85	85		
2.0		D	D	D	85	85	85	D	D	D	85	85	85	D	D	D	85	85	85	D	D	D	85	85	85	D	D		85	85		
3.0		D	D	D	85	85	85		D	D		85	85	D	D	D	85	85	85		D	D		85	85		D			85		
5.0		D	D	D	85	85	85			D			85		D	D		90	85		D	D		90	85							
8.0				D			90																									
12.0																																
20.0																																
1.0		D	D	D	85	85	85	D	D	D	85	85	85	D	D	D	85	85	85	D	D	D	85	85	85	D	D		85	85		
1.5		D	D	D	85	85	85	D	D	D	85	85	85	D	D	D	85	85	85	D	D	D	85	85	85	D	D		85	85		
2.0		D	D	D	85	85	85	D	D	D	85	85	85	D	D	D	85	85	85	D	D	D	85	85	85	D	D		85	85		
3.0		D	D	D	85	85	85		D	D		85	85	D	D	D	85	85	85		D	D		85	85		D			85		
5.0		D	D	D	85	85	85			D			85		D	D		90	85		D	D		90	85							
8.0				D			90																									
12.0																																
20.0																																
1.0		D	D	D	85	85	85	D	D	D	85	85	85	D	D	D	85	85	85	D	D	D	85	85	85	D	D		85	85		
1.5		D	D	D	85	85	85	D	D	D	85	85	85	D	D	D	85	85	85	D	D	D	85	85	85	D	D		85	85		
2.0		D	D	D	85	85	85	D	D	D	85	85	85	D	D	D	85	85	85	D	D	D	85	85	85	D	D		85	85		
3.0		D	D	D	85	85	85		D	D		85	85	D	D	D	85	85	85		D	D		85	85		D			85		
5.0			D	D			85	85			D			85		D	D		90	85		D	D		90	85						
8.0				D			90																									
12.0																																
20.0																																
1.0			D	D			85	85		D	D		85	85		D	D		85	85		D	D		85	85		D	D		85	85
1.5			D	D			85	85		D	D		85	85		D	D		85	85		D	D		85	85		D	D		85	85
2.0			D	D			85	85		D	D		85	85		D	D		85	85		D	D		85	85		D	D		85	85
3.0				D			85						85			D	D		85	85					85	85						
5.0					D			85									D			90												
8.0																																
12.0																																
20.0																																
1.0																																
1.5																																
2.0																																
3.0																																
5.0																																
8.0																																
12.0																																
20.0																																

Table B-16 Installation Type 2, DN ≥ 300. 0.5 bar Vacuum - Ground Water to Level
Minimum Backfill Compaction, % Standard Proctor Density. (D = Dumped, C = Compacted)

Type 2 DN ≥ 300		No Traffic Load – 1.0 bar Internal Vacuum – Ground Water To Level																							
		Standard Trench, Bd/D = 1.8												Wide Trench, Bd/D = 3.0								<= Native Soil			
Upper Backfill		SC3 85% SPD						SC4 95% SPD						SC3 85% SPD				SC4 95% SPD							
Backfill		SC1			SC2			SC1			SC2			SC1		SC2		SC1		SC2					
Pipe SN Burial Depth, m		2500	5000	10000	2500	5000	10000	2500	5000	10000	2500	5000	10000	2500	5000	10000	2500	5000	10000	2500	5000		10000		
		1.0		D	D		85	85			D		85			D		85			D	D		85	85
1.5		D	D	D	85	85	85			D		85			D	D		85	85						
2.0		D	D	D	85	85	85			D		85			D	D		85	85						
3.0			D	D		85	85								D			85							
5.0			D	D		85	85								D			85							
8.0				D			90																		
12.0																									
20.0																									
Group 1																									
1.0			D	D		85	85			D		85			D		85								
1.5		D	D	D	85	85	85			D		85			D	D		85	85						
2.0		D	D	D	85	85	85			D		85			D	D		85	85						
3.0			D	D		85	85								D			85							
5.0			D	D		85	85								D			85							
8.0				D			90																		
12.0																									
20.0																									
Group 2																									
1.0			D	D		85	85			D		85			D		85								
1.5		D	D	D	85	85	85			D		85			D	D		85	85						
2.0		D	D	D	85	85	85			D		85			D	D		85	85						
3.0			D	D		85	85								D			85							
5.0			D	D		85	85								D			85							
8.0				D			85																		
12.0																									
20.0																									
Group 3																									
1.0				D			85			D		85			D		85								
1.5		D	D	D	85	85	85			D		85			D	D		85	85						
2.0		D	D	D	85	85	85			D		85			D	D		85	85						
3.0			D	D		85	85								D			85							
5.0				D			85																		
8.0																									
12.0																									
20.0																									
Group 4																									
1.0				D			85			D		85													
1.5			D	D		85	85			D		85			D	D		85	85						
2.0			D	D		85	85			D		85			D			85							
3.0				D			85								D			85							
5.0																									
8.0																									
12.0																									
20.0																									
Group 5																									
1.0																									
1.5															D			85							
2.0															D			85							
3.0																									
5.0																									
8.0																									
12.0																									
20.0																									
Group 6																									
1.0																									
1.5																									
2.0																									
3.0																									
5.0																									
8.0																									
12.0																									
20.0																									

- 01
- 02
- 03
- 04
- 05
- 06
- 07
- 08
- 09
- 10
- app.

Table B-17 Installation Type 2, DN ≥ 300. 1.0 bar Vacuum - Ground Water to Level
 Minimum Backfill Compaction, % Standard Proctor Density. (D = Dumped, C = Compacted)

Appendix C

Classification and Properties of Native Soils

For the analysis of pipe installation requirements, the native soils are classified in six groups and related to stiffness through blow counts as defined by a standard penetration test using a split barrel sampler, ASTM D1586. These native soils, which form the trench walls, range from very stable, dense granular soils and very hard cohesive soils to relatively weak, fine grained soils. These same native soils may be considered for use as backfill.

- 1 Blows/foot from standard penetration test, ASTM D1586.
- 2 For higher blow counts, M_{sn} values increase to 345 MPa for rock.
- 3 When a geotextile pipe zone wrap is used, M_{sn} values for poor soils can be greater than those listed above.
- 4 When permanent solid sheeting designed to last the life of the pipeline is used in the pipe zone, the constrained soil modulus shall be based solely on the backfill modulus.

Correlation to other test methods

There are several different cone penetrometer tests in use around the world. With the potential for significant variations in these different tests, an approximate correlation to standard penetrometer blow counts, N , based on ASTM D1586 can be provided. With the output of the cone penetrometer test, q_u , expressed in kg/cm^2 the corresponding standard penetrometer blow count, N is:

$$N = q_u/4 \text{ for mechanical cone penetrometer}$$

$$N = q_u/3 \text{ for electrical cone penetrometer}$$

Representation of the native soil is given in **Table C-1**, which follows the general recommendations provided in AWWA M45. The blow count to be used is the lowest value found over an extended period of time in the pipe zone. Normally, the weakest condition of the soil exists when the soil has been subjected to wet conditions for an extended period.

Soil group	Granular		Cohesive		Modulus M_{sn}
	Blow count ¹	Description	q_u kPa	Description	
1	> 15	Compact	> 200	Very stiff	34.50
2	8 - 15	Slightly compact	100 - 200	Stiff	20.70
3	4 - 8	Loose	50 - 100	Medium	10.30
4	2 - 4		25 - 50	Soft	4.80
5	1 - 2	Very loose	13 - 25	Very soft	1.40
6	0 - 1	Very very loose	0 - 13	Very very soft	0.34

¹ Standard penetration test per ASTM D1586

Table C-1 Native Soil Stiffness Groups. Values of Constrained Modulus, M_{sn}

Appendix D Classification and Properties of Backfill Soils

To be used as backfill for pipes, the soil must provide stiffness to the pipe/soil system and maintain the required stiffness with time. The variety of potential soils that can be used as pipe zone backfill is limitless. Pipe zone backfill may be selected from the soil removed from the trench or may require special soils to be imported to the job site, if the trenched soils are not adequate to serve as backfill. The practical selection of a pipe zone backfill soil depends on ease of compaction to achieve the needed stiffness and availability.

Soils suitable to be used as backfill materials are classified in 4 stiffness categories.

Soil Stiffness Category 1, SC1

SC1 materials provide maximum pipe support for a given compaction due to low content of sand and fines. With minimum effort these materials can be installed at relatively high stiffness over a wide range of moisture contents. In addition, the high permeability of SC1 materials may aid in the control of water and are often desirable for embedment in rock cuts where water is frequently encountered.

However, when groundwater flow is anticipated, consideration should be given to the potential of migration of fines from adjacent materials into the open graded SC1 material, see section A.8 →.

Soil Stiffness Category 2, SC2

SC2 materials, when compacted, provide a relatively high level of pipe support. However, open graded groups may allow migration and should be checked for compatibility with adjacent materials, see section A.8 →.

Soil Stiffness Category 3, SC3

SC3 materials provide less support for a given density than SC1 or SC2 materials. Higher levels of compaction effort are required and moisture content must be near optimum to achieve the required density. These materials provide a reasonable level of pipe support once proper density has been achieved.

Soil Stiffness Category 4, SC4

SC4 materials require geotechnical evaluation prior to use. The moisture content must be near optimum to achieve the required density. When properly placed and compacted, SC4 materials can provide a reasonable level of pipe support. These materials are, however, not suitable for deep burial depths and traffic loads or for compaction with high energy vibratory compactors and tampers. SC4 materials should not be used where water conditions in the trench prevent proper placement and compaction. General guidelines for classifying backfill soils in stiffness categories are given in **Table D-1**.

For any given backfill stiffness category the higher the compaction the higher the soil modulus and the higher the support. In addition, the soil modulus also increases with the vertical soil stress level i.e. with burial depth. **Table D-2** to **Table D-5** give the M_{sb} values for backfill stiffness categories SC1, SC2, SC3 and SC4 as a function of the % Standard Proctor Density (SPD) and vertical stress level. The values apply for pipes installed above the groundwater level.

For pipes installed below groundwater level, the constrained soil modulus will be reduced for lower stiffness class soils and lower compaction, see values in parenthesis. The vertical stress level is the vertical effective soil stress at the pipe springline elevation. It is normally computed as the design soil unit weight times the depth of fill. Buoyant unit weight should be used below the groundwater level.

The German static calculation method for buried pipes ATV 127 is frequently used. As an aid, the following is the correlation

Backfill Soil Stiffness Category	Description of Backfill Soils
SC1	Crushed rock with < 15% sand, maximum 25% passing the 9.5 mm sieve and maximum 5% fines ²⁾ .
SC2	Clean, coarse-grained soils: SW, SP ¹⁾ , GW, GP or any soil beginning with one of these symbols with 12% or less fines ²⁾ .
SC3	Clean, coarse-grained soils with fines: GM, GC, SM, SC or any soil beginning with one of these symbols with 12% or more fines ²⁾ . Sandy or gravely fine-grained soils: CL, ML, (or CL-ML, CL/ML, ML/CL) with 30% or more retained on a no. 200 sieve
SC4	Fine grained soils: CL, ML, (or CL-ML, CL/ML, ML/CL) with 30% or less retained on a no. 200 sieve

Note: Symbols in table are according to the Unified Soil Classification Designation, ASTM D2487
 1) Uniform fine sand, SP, with more than 50% passing no. 100 sieve (0.15 mm) is very sensitive to moisture and is not recommended as backfill.
 2) % fines is the weight percentage of soil particles that pass no. 200 sieve with 0.076 mm opening

Table D-1 Backfill Soil Type Classification

Burial Depth (Soil Density 18.8 kN/m ³)	Vertical Stress Level	Compaction, % maximum Standard Proctor Density	
		Compacted	Dumped
m	kPa	MPa	MPa
0.4	6.9	16.2	13.8
1.8	34.5	23.8	17.9
3.7	69.0	29.0	20.7
7.3	138.0	37.9	23.8
14.6	276.0	51.7	29.3
22.0	414.0	64.1	34.5

Table D-2 M_{sb} for SC1 Backfill Soil

Burial Depth (Soil Density 18.8 kN/m ³)	Vertical Stress Level	Compaction, % maximum Standard Proctor Density			
		100	95	90	85
m	kPa	MPa	MPa	MPa	MPa
0.4	6.9	16.2	13.8	8.8 (7.5)	3.2 (2.4)
1.8	34.5	23.8	17.9	10.3 (8.8)	3.6 (2.7)
3.7	69.0	29.0	20.7	11.2 (9.5)	3.9 (2.9)
7.3	138.0	37.9	23.8	12.4 (10.5)	4.5 (3.4)
14.6	276.0	51.7	29.3	14.5 (12.3)	5.7 (4.3)
22.0	414.0	64.1	34.5	17.2 (14.6)	6.9 (5.2)

Table D-3 M_{sb} for SC2 Backfill Soil (reduced values below ground water table in parenthesis)

Burial Depth (Soil Density 18.8 kN/m ³)	Vertical Stress Level	Compaction, % maximum Standard Proctor Density			
		100	95	90	85
m	kPa	MPa	MPa	MPa	MPa
0.4	6.9	-	9.8 (4.9)	4.6 (2.3)	2.5 (1.3)
1.8	34.5	-	11.5 (5.8)	5.1 (2.6)	2.7 (1.4)
3.7	69.0	-	12.2 (6.1)	5.2 (2.6)	2.8 (1.4)
7.3	138.0	-	13.0 (6.5)	5.4 (2.7)	3.0 (1.5)
14.6	276.0	-	14.4 (7.2)	6.2 (3.1)	3.5 (1.8)
22.0	414.0	-	15.9 (8.0)	7.1 (3.6)	4.1 (2.1)

Table D-4 M_{sb} for SC3 Backfill Soil (values below ground water level in parenthesis)

Burial Depth (Soil Density 18.8 kN/m ³)	Vertical Stress Level	Compaction, % maximum Standard Proctor Density			
		100	95	90	85
m	kPa	MPa	MPa	MPa	MPa
0.4	6.9	-	3.7 (1.11)	1.8 (0.54)	0.9 (0.27)
1.8	34.5	-	4.3 (1.29)	2.2 (0.66)	1.2 (0.36)
3.7	69.0	-	4.8 (1.44)	2.5 (0.75)	1.4 (0.42)
7.3	138.0	-	5.1 (1.53)	2.7 (0.81)	1.6 (0.48)
14.6	276.0	-	5.6 (1.68)	3.2 (0.96)	2.0 (0.60)
22.0	414.0	-	6.2 (1.86)	3.6 (1.08)	2.4 (0.72)

Table D-5 M_{sb} for SC4 Backfill Soil (values below ground water level in parenthesis)

! Note: M_{sb} values at intermediate vertical stress levels not given in **Table D-2** to **Table D-5** can be obtained by interpolation. The % maximum standard proctor density indicates the dry density of the compacted soil as a percentage of maximum dry density determined in accordance with ASTM D 698.

between the backfill soil stiffness categories of these instructions and the ATV 127 soil groups, G1 to G4: SC1 corresponds to the best of the G1 soils. SC2 corresponds to the G1 soils and the best of the G2 soils.

SC3 corresponds to the weaker G2 soils and the best of the G3 soils. SC4 corresponds to the weaker G3 soils and the best of the G4 soils.

Appendix E Field Testing to assist Classification of Native Soils

Native Soil Characteristic	Measurable Group
1	Can be barely penetrated with thumb
2	Can be penetrated with thumb to 4 mm
3	Can be penetrated with thumb to 10 mm
4	Can be penetrated with thumb to 25 mm
5	Can be penetrated by thumb to 50 mm
6	Can be penetrated by fist to 25 mm

Table E 1 Simple Field Test Determining Soil Group¹⁾

¹⁾ Based on Peck, Hanson and Thornburn, "Foundation engineering", 2nd Ed., John Wiley and Sons, Inc., 1974 and ASTM D2488.

Appendix F Compaction of Backfill

This appendix provides helpful tips for compacting the various types of backfill. The maximum and minimum allowable installation depths will be effected by the selection and compaction of pipe zone backfill. The stiffer the soil, the deeper a given pipe can be installed to achieve a limited deflection or vacuum. This guide offers a general background for soil behaviour to provide a better understanding of our installation criteria. Include considerations for seasonal variations when assessing the potential for moisture content of both in situ and backfill soils. The compaction value recommended to provide a soil modulus value is to be considered as a minimum value and field densities should be at or higher than the requirement.

As a means of "calibrating" an installation method with a given backfill type, we recommend that specific attention be given to compaction techniques and relative compaction result during the installation of the initial sections of pipe used at a given installation site. By correlating the resulting compaction as a function of the soil type, method of placement of soil in the haunch zones and side fill areas, compaction methods for haunch and side fill areas, lift heights used, moisture content and number of passes, a good "feel" for the efforts needed for installation can be determined. When these initial pipes are installed, testing should be conducted frequently to assure

compaction and pipe deflection criteria are being achieved. With this correlation, a technique for compacting a given soil type can be "calibrated" and the frequency for testing can be reduced. With this correlation, the workers gain a good understanding of the requirements for proper installation when using a specific backfill type for a specific set of requirements. (ASTM D5080 offers a reasonable method for rapidly measuring field density and moisture content of soils.) There are many methods available for measuring field density of the compacted backfill.

A measurement of the increase in the vertical diameter of the pipe is a reasonable measure of compaction effort used during the installation and another good "calibration" measurement. If backfill has been properly placed and compacted in the haunch areas of the pipe, a good method for judging compaction is the vertical diameter measurement when the backfill placement has reached the top of the pipe (or at any stage if consistently monitored). However, be aware that when using high levels of compaction effort, excessive vertical increase in diameter may result. If this condition occurs, contact the pipe supplier for assistance, and do not continue with the installation using the method that creates the excessive increase in vertical diameter.

Pipe zone backfill materials should be placed and compacted in uniform lifts on both sides of the pipe. For backfill placement and compaction in the haunch areas, start compacting under the pipe and work away from the pipe. For side fill, compaction usually progresses best when the backfill is compacted at the trench wall first and compaction progresses toward the pipe. Usually the number of "passes" or repeated applications of the compaction equipment (at a constant rate of movement) will increase the compaction. A good way to determine a sufficient compaction method is to measure the compaction and other response measurements as a function of the number of passes of a given compaction device. Use the number of passes and other criteria such as moisture content and vertical deflection as a means of controlling the installation procedure. If the compaction equipment is changed, the number of passes to achieve the specified compaction may be affected. Heavier and wider plate vibrators typically compact deeper and to a higher degree than lighter and narrower ones. Likewise, the smaller and lighter impact compactors have a less effective depth than the larger, heavier ones.

Compaction over the top of the pipe must assure that there is sufficient material to not impact the pipe. At least 150 mm cover should be sufficient when using a hand operated plate vibrator compactor; however, 300 mm is recommended when using a hand operated impact compactor. A compaction of no more than 85% SPD can realistically be achieved when compacting the first 300mm lift directly over the pipe crown (top).

Backfill soils that are granular in character provide relatively high stiffness with minimal compaction effort. Compact

granular soils have little tendency to creep or consolidate with time. Granular soils are less sensitive to moisture, both at the time of placement and during long-term use. When finer grained soils are used as backfill, the support for the pipe is typically reduced. Granular soil with more than 12% by weight of fines (soils with particle size less than 75 microns) are significantly affected by the characteristic of the finer materials. If the fines are mostly silts (37 to 75 microns), the typical soils are moisture sensitive, have a tendency to be transported by flowing water and require some additional effort to compact. If the fines are mostly clay (less than 37 microns and cohesive), the soils are more moisture sensitive, which reduces stiffness, and the soil will creep with time. Typically, more compaction effort is needed to achieve the required density. By limiting soils to a liquid limit of 40%, the highly moisture sensitive and plastic soils will be eliminated from use.

Backfill Types SC1 and SC2 are relatively easy to use and very reliable as backfill materials for pipe. These soils have low moisture sensitivity. Backfill can be easily compacted using a plate vibrator compactor in 200 to 300 mm lifts. Occasionally, a filter fabric should be used in combination with gravel soils to preclude fines migration and subsequent loss of pipe support. See Section A.8 for criteria [→](#).

Backfill Type SC3 soils are acceptable and often readily available as backfill materials for pipe installations. Many local soils, in which the pipe is installed, are Type SC3 and therefore the trenched soil can be directly reused as pipe-zone backfill. Care is to be taken with these soils as they can be moisture sensitive. The characteristics of Type SC3 soil are often dictated by the characteristics of the fines. Moisture control may be required when compacting the soil to achieve the desired density with reasonable compaction energy and easily used compaction equipment. Compaction can be achieved by using an impact compactor in 100 to 200 mm lifts.

Backfill type SC4 can only be used as pipe-zone backfill with the following precautions:

- Moisture content must be controlled during placement and compaction.
- Do not use in installations with unstable foundations or with standing water in the trench.
- Compaction techniques may require considerable energy, and practical limitations of relative compaction and resulting soil stiffness must be considered.
- When compacting, use lifts of 100 and 150 mm with an impact compactor such as Whacker or pneumatic rammer (pogo stick).
- Compaction tests should be conducted periodically to assure proper  at compaction is achieved. See Appendix F for further information [→](#).

The compaction of finer grain backfill is most easily accomplished when the material is at or near its optimum moisture content.

When backfilling reaches pipe springline, all compaction should start near the trench sides and proceed towards the pipe.

It is recommended that placing and compacting of the pipe zone backfill is done in such a way as to cause the pipe to ovalise slightly in the vertical direction. Initial vertical ovalisation, however, must not exceed 1.5% of pipe diameter as measured when backfill reaches pipe crown. The amount of initial ovalisation obtained will be related to the energy required to achieve the relative compaction needed. The high energy levels that may be necessary with backfill Types SC3 and SC4 may lead to exceeding the limit. If this occurs consider a higher stiffness pipe or other backfill materials or both.

Appendix G

Definitions and Terminology

Term	Description
Nominal diameter, DN	The diameter classification of pipe, expressed in mm.
Nominal Pressure, PN	The pressure rating of a pipe, expressed in bars or pressure.
Nominal Stiffness, SN	The minimum initial specific stiffness, EI/D^3 , of a pipe as measured by a load required to deflect a pipe ring, expressed in N/m^2 .
Pipe crown	The top inside surface of the pipe.
Pipe invert	The bottom inside surface of a pipe.
Depth of bury	The depth of cover over the top of a pipe.
Deflection	The change in vertical diameter typically expressed as a percentage of the nominal pipe diameter.
Springline	The mid height of the pipe, the 90 and 270 degree locations of a pipe as measured from the top centre of the pipe.
Constrained soil modulus, M_s	A secant modulus of soil measured by a one dimensional compression test used to describe soil stiffness.
Standard Proctor Density, SPD	The maximum dry density obtained at optimum moisture content when tested by ASTM D698, used to define 100% standard proctor density.
Percent Standard Proctor Density	The achieved dry density/maximum dry density expressed in %.
Blow Counts	The number of impacts of a 140 pound (64 kg) hammer dropping 30 inches (76 cm) to drive a split barrel sampler 12 inches (30 cm) by ASTM D1586.

Appendix H

Approximate Weights for Pipes and Couplings

DN	Gravity				PN 6				PN 10				PN 16			
	SN 2500	SN 5000	SN 10000	Coupling	SN 2500	SN 5000	SN 10000	Coupling	SN 2500	SN 5000	SN 10000	Coupling	SN 2500	SN 5000	SN 10000	Coupling
mm	kg/m	kg/m	kg/m	kg	kg/m	kg/m	kg/m	kg	kg/m	kg/m	kg/m	kg	kg/m	kg/m	kg/m	kg
100					-	-	2.5	2.0	-	-	2.5	2.0	-	-	2.5	2.0
150					-	-	4.9	3.0	-	-	4.9	3.0	-	-	4.9	3.0
200					-	-	7.2	4.0	-	-	7.2	4.0	-	-	7.2	4.0
250					-	-	10.8	6.0	-	-	10.8	6.0	-	-	10.8	6.0
300	9.1	11.3	14.1	7.0	8.2	10.4	12.7	13.0	7.9	10.3	12.7	13.7	7.5	9.5	12.2	14.1
350	12.2	15.1	18.9	8.0	11.1	14.3	17.3	15.0	10.6	13.8	17.3	15.8	10.0	12.6	16.3	16.4
400	15.5	19.4	25.0	9.0	14.5	18.5	23.0	16.8	13.5	17.6	23.0	17.9	12.6	16.1	21.0	18.5
450	19.4	25.0	30.0	10.1	18.4	24.0	29.0	18.8	16.8	22.0	29.0	19.6	15.8	19.9	26.0	21.0
500	24.0	30.0	37.0	11.1	23.0	30.0	35.0	21.0	21.0	27.0	35.0	22.0	19.3	25.0	32.0	23.0
600	33.0	41.0	50.0	12.8	32.0	40.0	48.0	32.0	28.0	37.0	48.0	34.0	26.0	33.0	44.0	35.0
700	44.0	55.0	67.0	15.2	43.0	54.0	66.0	37.0	38.0	49.0	66.0	39.0	35.0	45.0	59.0	42.0
800	57.0	71.0	87.0	18.1	55.0	69.0	86.0	42.0	49.0	64.0	86.0	46.0	45.0	58.0	76.0	50.0
900	72.0	88.0	115.0	21.0	70.0	87.0	110	48.0	61.0	81.0	110.0	53.0	56.0	73.0	95.0	58.0
1000	88.0	110.0	140.0	24.0	86.0	110.0	135.0	54.0	75.0	100.0	135.0	60.0	69.0	89.0	120.0	66.0
1200	130.0	160.0	200.0	30.0	125.0	155.0	195.0	66.0	110.0	145.0	195.0	74.0	98.0	130.0	170.0	81.0
1400	175.0	215.0	270.0	37.0	170.0	210.0	260.0	78.0	145.0	195.0	260.0	88.0	135.0	175.0	230.0	100.0
1600	230.0	280.0	345.0	44.0	220.0	270.0	340.0	90.0	190.0	255.0	340.0	105.0	175.0	225.0	295.0	125.0
1800	290.0	355.0	440.0	51.0	275.0	345.0	425.0	105.0	240.0	320.0	425.0	120.0	220.0	285.0	375.0	
2000	355.0	435.0	540.0	61.0	340.0	420.0	530.0	120.0	295.0	390.0	530.0	135.0	270.0	350.0	460.0	
2200	425.0	530.0	650.0	71.0	410.0	510.0	640.0	130.0	355.0	470.0	640.0	155.0	320.0	420.0	560.0	
2400	510.0	630.0	770.0	82.0	485.0	610.0	750.0	145.0	420.0	560.0	750.0	170.0	380.0	495.0	660.0	
2600	600.0	740.0	910.0	110.0	570.0	710.0	890.0	280.0	490.0	660.0	890.0	325.0	445.0	580.0	770.0	
2800	690.0	850.0	1050.0	120.0	660.0	820.0	1030.0	310.0	570.0	760.0	1030.0	355.0	520.0	680.0	900.0	
3000	790.0	970.0	1210.0	135.0	760.0	940.0	1170.0	335.0	650.0	870.0	1170.0	385.0	580.0	770.0	1030.0	

DN	PN 20				PN 25				PN 32			
	SN 2500	SN 5000	SN 10000	Coupling	SN 2500	SN 5000	SN 10000	Coupling	SN 2500	SN 5000	SN 10000	Coupling
mm	kg/m	kg/m	kg/m	kg	kg/m	kg/m	kg/m	kg	kg/m	kg/m	kg/m	kg
300	7.4	9.3	11.8	16.7	-	9.2	11.5	16.7	-	-	11.3	16.7
350	9.9	12.3	15.6	19.3	-	12.2	15.4	19.3	-	-	15.0	19.3
400	12.6	15.8	21.0	19.3	-	15.5	19.6	19.9	-	-	19.0	22.0
450	15.5	19.6	26.0	22.0	-	19.1	25.0	22.0	-	-	24.0	25.0
500	18.9	24.0	31.0	23.0	-	24.0	30.0	24.0	-	-	29.0	27.0
600	26.0	32.0	42.0	36.0	-	32.0	40.0	39.0	-	-	39.0	44.0
700	34.0	43.0	56.0	45.0	-	42.0	54.0	47.0	-	-	52.0	56.0
800	44.0	56.0	72.0	53.0	-	55.0	70.0	54.0	-	-	68.0	66.0
900	55.0	70.0	91.0	60.0	-	68.0	88.0	64.0	-	-	85.0	95.0
1000	67.0	86.0	115.0	68.0	-	84.0	110.0	79.0	-	-	105.0	115.0
1200	96.0	125.0	160.0	90.0	-	120.0	155.0	110.0	-	-	150.0	135.0
1400	130.0	165.0	220.0	120.0	-	165.0	210.0	145.0	-	-	205.0	170.0

Appendix I Joint Lubricant Requirements

Nominal Pipe Diameter (mm)	Nominal Amount of Lubricant (kg) Required per Joint
100 to 250	0.050
300 to 500	0.075
600 to 800	0.10
900 to 1000	0.15
1100 to 1200	0.20
1300 to 1400	0.25
1500 to 1600	0.30
1800	0.35
2000	0.40
2200	0.45
2400	0.50
2600	0.55
2800	0.60
3000	0.65

Note: Lubricants amounts are based on lubricating two gaskets and two spigot ends per joint. Factory pre-assembled coupling joints will only require half the above amounts per joint.

Appendix J Cleaning of Flowtite Sewer Pipe

There are several methods used to clean gravity sewer lines, depending on diameter and the degree and nature of blockage. All of these methods use either mechanical means or water jet to clean the interior of the pipe. When mechanical means are employed, we recommend the use of plastic scrapers to avoid damage to the pipe's inner surface.

The use of high pressure water, emitted through jet nozzles, is a practice followed in some countries for cleaning sewer pipes. However, water emitted under high pressure through a jet nozzle can cause damage to most materials if not properly controlled. Based on experience gained with water jet cleaning of GRP sewer pipes, the following guidelines must be adhered to in order to avoid damage to the installed pipes.

Cleaning of Sewer and Pressure-Sewer Pipes (FS and FPS)

- 1 Maximum input to 120 bars*. Due to the smooth interior surface of GRP pipe, adequate cleaning and removal of blockages can normally be achieved below this pressure.
- 2 Nozzles with jet holes around the circumference are to be preferred. Nozzles with cleaning chains or wires, as well as rotating, aggressive or damaging nozzles are to be avoided.
- 3 The water discharge angle should not be greater than 30°. A smaller angle than 20° is usually sufficient for GRP pipe, as the smooth surface of the material inhibits adhesion, and only washing of the interior is of essence.
- 4 The number of jet holes should be 6 to 8 and hole size must be at least 2.4 mm.
- 5 The external surface of the nozzle shall be smooth and the maximum weight 4.5 kg. Nozzle length corresponding that weight should be at least 170 mm. For small and medium range diameters (DN100 – 800) lighter nozzles (approximately 2.5 kg) shall be used.
- 6 The forward and backward moving speed of the nozzle shall be limited to 30 m/min. Uncontrolled movement of the nozzle is not allowed. When inserting the nozzle into the pipe care should be taken to prevent it from hitting the pipe wall.

7 Jetting/swabbing sleds with several runners give a greater distance between nozzle and pipe wall, resulting in a less aggressive cleaning.

8 The use of equipment or pressures that do not meet the above criteria could cause damage to the installed pipe.

Minor, local chipping of the surface of the abrasion layer are not considered to have detrimental effect on the operational performance of the pipe.

For further questions please consult the supplier.



Figure J-1 Nozzle with jet holes around the circumference, 4.5 kg



Figure J-2 Nozzle with jet holes around the circumference, 2.5 kg

*The cleaning is only allowed to be done with a jet-power-density of 600 W/mm². Experiences have shown that if one uses the set up nozzle and jet holes and a flow rate of 300 l/min, a pressure of 120 bars will occur. "

Cleaning of Pressure Pipes (FP)

These guidelines are to be used when Flowtite pressure pipes (FP) are used in sewer applications.

- 1** Maximum input to 80 bars. Due to the smooth interior surface of GRP pipe, adequate cleaning and removal of blockages can normally be achieved below this pressure.
- 2** Nozzles with jet holes around the circumference are to be preferred. Nozzles with cleaning chains or wires, as well as rotating, aggressive or damaging nozzles are to be avoided.
- 3** The water discharge angle must be between 6° and 15° relative to the pipe axis.
- 4** The number of jet holes should be 6 to 8 or more and holes size must be at least 2.4 mm.
- 5** The external surface of the nozzle shall be smooth and the maximum weight 2.5 kg.
- 6** The forward and backward moving speed of the nozzle shall be limited to 30 m/min. Uncontrolled movement of the nozzle is not allowed. When inserting the nozzle into the pipe care should be taken to prevent it from hitting the pipe wall.
- 7** Jetting/swabbing sleds with several runners give a greater distance between nozzle and pipe wall are required (see **Figure J-3**).
- 8** The use of equipment or pressures that do not meet the above criteria could cause damage to the installed pipe.

For further questions please consult the supplier.

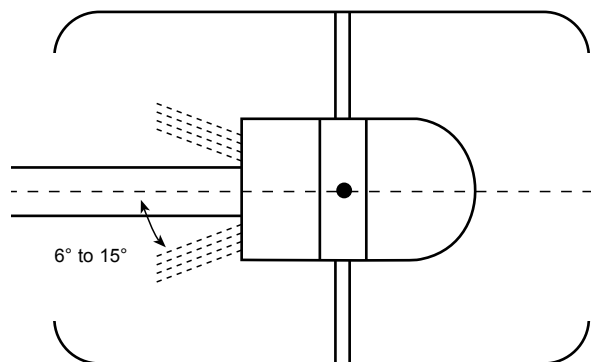
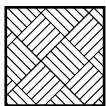

Figure J-3 Jetting/swabbing sleds

This Installation Guide for Buried Pipe is the intellectual property of FTEC. All rights reserved.

No part of this Installation Guide may be reproduced, stored in a retrieval system, or transmitted in any form or by any means, electronic, mechanical, photocopying, recording or otherwise without the prior permission of the intellectual property owner.

Profiles for Fillings



Bedding / Foundation compacted

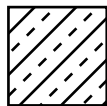

Concrete

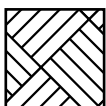

Bedding / Foundation

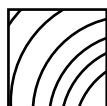

Wood

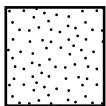

Backfill

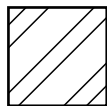

Stone

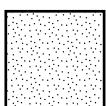

Backfill compacted

This handbook is intended as a guide only. All values listed in the product specifications are nominal. Unsatisfactory product results may occur due to environmental fluctuations, variations in operating procedures, or interpolation of data. We highly recommend that any personnel using this data have specialised training and experience in the application of these products and their normal installation and operating conditions. The engineering staff should always be consulted before any of these products are installed to ensure the suitability of the products for their intended purpose and applications. We hereby state that we do not accept any liability, and will not be held liable, for any losses or damage which may result from the installation or use of any products listed in this handbook as we have not determined the degree of care required for product installation or service. We reserve the right to revise this data, as necessary, without notice. We welcome comments regarding this handbook.



Flowtite Technology AS
P.O. Box 2059
3202 Sandefjord
Norway
Phone: + 47 33 44 91 58
Fax: + 47 33 46 26 17
info@amiantit.com
www.flowtite.com
www.amiantit.com

Distributed by: ■