

AMIPOX AMIPOX GRE Pipe systems

Glass Reinforced Epoxy Pipe Solutions for various Applications



AMIATIT PIPE SYSTEMS

Amiantit

Group of Companies

The Amiantit Group is an internationally operating organisation with a track record of growth oriented success. Its mission is to provide customers throughout the world with pipe solutions for water, sewage, gas, oil and industrial applications. In addition, the Group provides pipe technologies, water management services and building materials of superior quality and value. The company has a convincing history of long-term growth and profitability and a competitive position, thanks to the experience and commitment of its staff. Therefore we can look forward with confidence to achieving our vision of global leadership. Faced with the challenges of globalisation, Amiantit has dramatically expanded its international presence in recent years. A multicultural management team with a shared vision guarantees an extensive product range. Our customers are serviced by many local sales organisations worldwide. The manufacturing sites branded as "Amitech" provide customers all over the world with exclusive products of high quality.

Amipox Dammam

The first address for pipe systems and technical solutions

Our newly installed manufacturing site for Amipox products in Dammam provides customers and sales offices all over the world with an extended pipes and consulting service.

The facility is a substantial and long-term partner for customers and sales organisations, based on a dedicated and well qualified staff, a substantial ownership structure and a strong financial platform. We offer an extensive product range and service that covers almost every need for pipes and technical solutions.

As supplier of complete solutions for pipe systems to many applications, we provide you with high quality products. Our modern and effective production facility offers cost effective products and meets all required service and support standards.

Our up to date logistic system works effectively all over the world and guarantees a reliable and fast supply of all products to clients and customers.

Production

The Amipox GRE pipes and fittings are made of high strength fiberglass (E-glass) and amine cured epoxy resin. These materials provide the optimal strength in composite pipe systems.

Numerically controlled machines manufacture the product on a mandrel in a cross section filament winding process. The continuous glass fibres are wound at a $54 \frac{3}{4}^{\circ}$ helical angle and connected with the epoxy resin. This process, combined with the most modern equipment, ensures a consistent production of the highest quality. For certain applications, the pipe wall contains an extra liner of 0.5 mm. This optional resin rich liner consists of C-glass (C-veil) and the same resin as used in the pipe wall. Conductive pipes and fittings are available on request.

Amipox pipes are manufactured according to metric dimensional standards. All pipe systems are interchangeable with steel pipes. The wide range of fittings provided by Amipox ensures that pipe design according to standard procedures is possible.



Benefits

The product range of Amipox GRE pipe systems combines many advantages in one product. GRE is a corrosion free material. Coatings (internal or external), chemical inhibitors, cathodic protection and corrosion allowances are not required. The life time of pumps and other inline equipment is extended through the complete absence of rust particles.

The low thermal conductivity of GRE ensures low energy losses from the pipe system. In many cases insulation can therefore be avoided. Amipox pipes have a very smooth inside surface resulting in a Hazen Williams factor of 150. This allows in most cases a smaller pipe diameter for any given volume, which cuts costs of the system. Paraffin, resin and asphalt accumulation in crude oil transmission lines is also reduced, thanks to the very low internal friction.

Better wall-thickness/strengths ratios are achieved through the high precision winding technology used by Amipox. This results in lower weight per pressure classes. Amipox AL and ALR joints are future (patented) developments to guarantee a fast and trouble free installation on site. Amipox pipes can be used for above and underground applications. The life cycle of GRE exceeds stainless steel.

Corrosion resistant

- No coating
- No cathodic protection
- Handles hundreds of corrosive chemicals

Lightweight

- Low pipe weight (less than 20% compared to steel)
- Easy to handle
- Lower installation costs
- Lighter structure

Low pressure loss

- Smooth inner surface
- Absolute roughness 5.3×10^{-6} m
- Hazen Williams factor 150
- No increase over time

Good economics

- Low installation costs
- Low heat loss
- Maintenance free lines
- Very low pigging and line cleaning costs
- Long service life
- Standard range of fittings and flanges
- Lower pumping cost

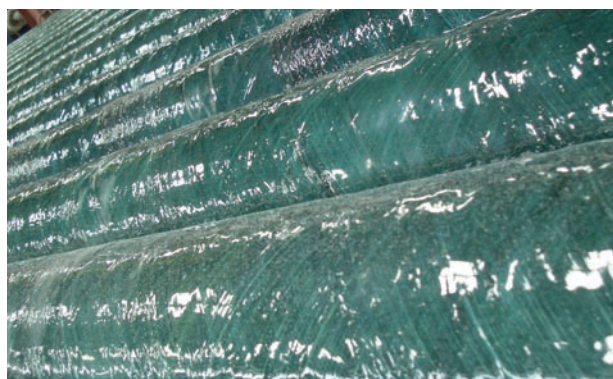
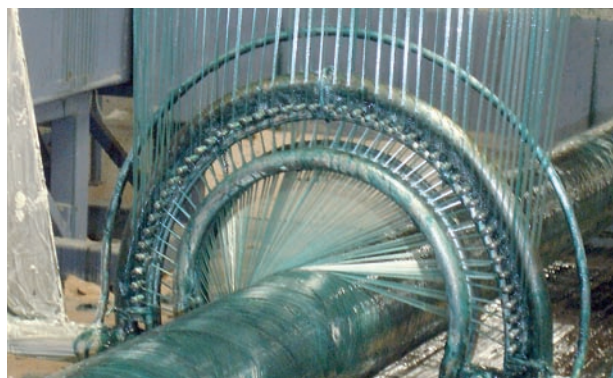
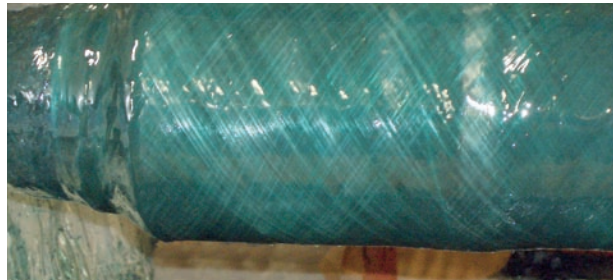
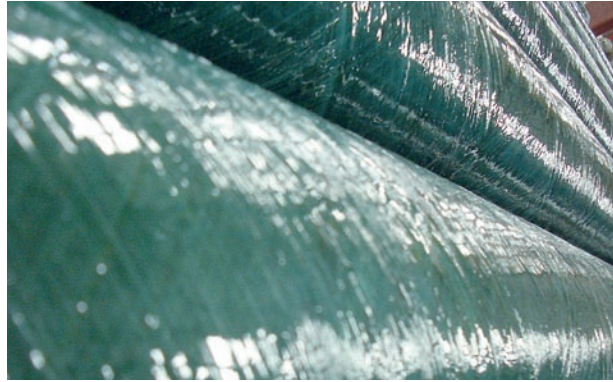

Applications

Amipox pipes are designed for pressures ranging from 10 bar (150 psi) to 150 bar (2000 psi) and medium temperatures from -40°C (-50°F) to +120°C (+250°F). As indicated in the list of general applications, Amipox pipes are suitable for the transportation of hundreds of highly corrosive chemicals. GRE pipes have proven to be the best solution in the petrochemical industry, marine (onshore and offshore) and in industrial applications, where reliability and strength are key factors.

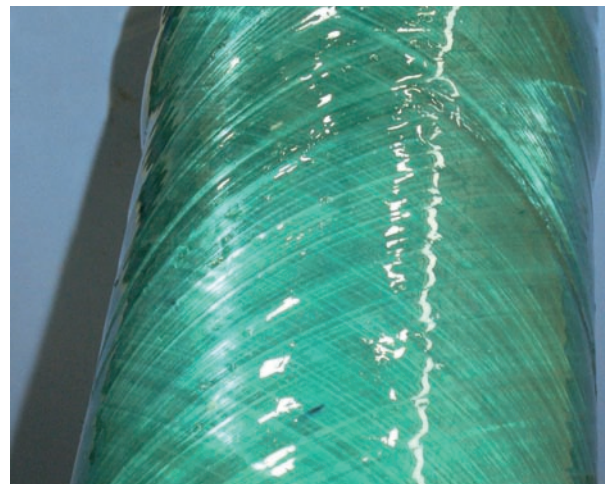

Industrial applications

Industrial plants:

- Chemical processing
- Fertilizer plants
- Food processing
- Geothermal systems
- Paper and textile manufacture
- Petrochemical processing
- Mining
- Exhaust piping lines

Oilfield production:

- Carbon dioxide injection and gathering
- Crude oil flow lines, gathering lines and transmission lines
- Low pressure gas gathering lines
- Tank battery piping
- Submerged pump-well tubing
- Tubing and casing

Service Stations:

- Bulk plant terminals
- Central fuel oil systems
- Marinas and airports
- Secondary containment
- Service station product piping
- Jet engine air start systems

Power stations:

- Cooling water lines
- Fire water lines
- Utility lines
- Electrical conduit lines

Marine and Offshore:

- Ballast lines
- Non-vital shipboard systems
- Dry and wet deluge systems on platforms

Utility:

- Agriculture
- Desalination water treatment
- SWRO plants
- Public service facilities

Fluids and chemicals (excerpt):

- Acid drains
- Alkalis
- Bilge water
- Bleaches and dyes
- Brackish water brine
- Chilled water
- Chlorine gas/chlorine
- Cooling circulating water
- Crude oil
- De-ionized water
- De-mineralized water
- Drainage fluids
- Education fluids
- Engine cooling fluids
- Fuel
- Hot water (120°C)
- Hydrochloric acid
- Injection water
- Jet fuel
- Oily sewers
- Organic chemicals
- Other caustic chemicals
- Petroleum
- Phosphoric acid
- Pickling fluids
- Potable water
- Process water
- Refined fluids
- Salt water
- Sanitary fluids
- Seawater
- Slurries
- Solvents
- Various oxidizing acids
- Various non-oxidizing acids

Product range

Amipox manufactures a complete range of glass reinforced Epoxy Pipe Systems, including a full range of fittings. The pipes are available in standard lengths of 9 m (30 ft, 80-600 mm diameter).

Pipes and fittings have been tested in accordance with ASTM D-2992 and comply with the ASTM D-2996 specification. Amipox pipes and fittings are in compliance with the ISO 14692 (Parts 1, 2, 3 and 4), API requirements (15 LR & HR). They meet FM (factory mutual) approval for fire protection and the NSF certification for drinking water use.



Type	Joint design	Design pressure		M _{px} temperature		Major use and application
		Bar	PSI	Degree °C	Degree F	
AB	Adhesive	16	230	120	250	General industrial
AT	Adhesive	10-100	145-1450	120	250	Crude oil flow-lines water injection
ASL	Mechanical	10-70	145-1015	93	200	Industrial services

Fittings and accessories



Amipox offers a complete line of filament wound fittings and flanges.

Standard fittings and flanges as listed below are available in diameters ranging from 25 mm (1") to 400 mm (16"):

- 90° Elbows
- Couplings
- 45° Elbows
- 45° Laterals
- Equal tees
- Nipples
- Reducers
- Flanges

Other fittings can be produced as segmented and laminated products. These fittings are manufactured up to DN 600 mm.

Spools



We also offer prefabricated spools on request. The main advantages are:

- Less field connections
- Lower installation costs
- The ability to hydro test spools prior to shipment

Joining Systems

Our sales and manufacturing team provides you with a wide range of joints, developed for all types of applications. These joining systems can be divided into three basic categories:

1. Adhesive joints

- AB series, adhesive bonded straight-taper joint, max. pressure rating 16 bar.
- AT series, adhesive bonded taper-taper joint, max. pressure rating 100 bar.

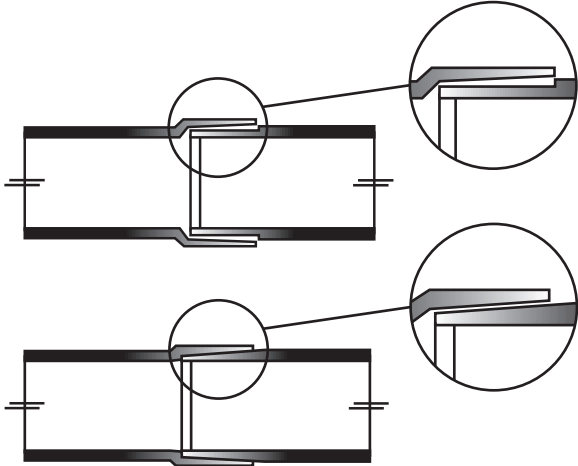

2. Mechanical joints

- ASL series seal-lock joint, O-ring with locking key, max. pressure rating 70 bar.

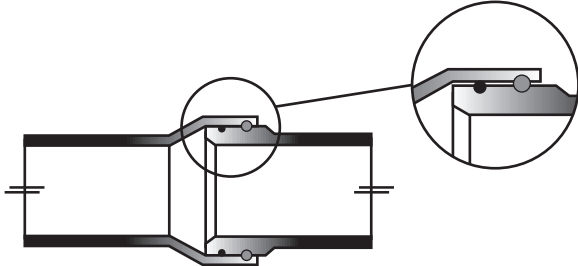

3. Flange joints

- Flange joint standard and heavy duty with 3 mm flat gasket, max. pressure rating 30 bar.
- Flange joint, with O-ring sealing, max. pressure rating 60 bar

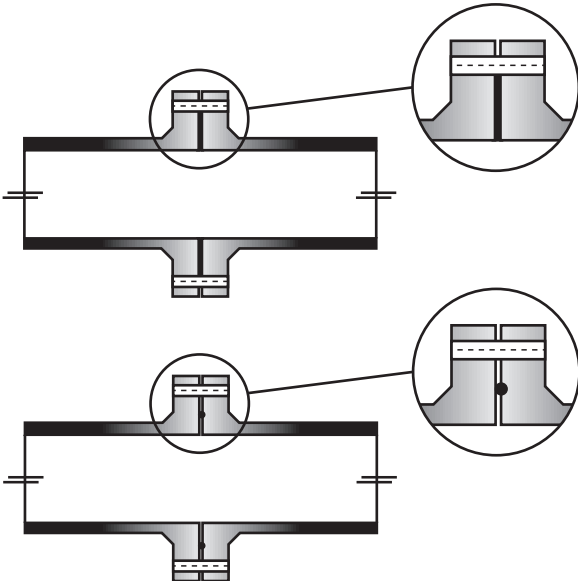

Services

Throughout the world, specialists at our sales offices offer a wide range of product support. They will assist and advise on:

- Planning, installation and rehabilitation
- Local consultation and support for contractors
- Static and hydraulic calculation
- Solutions for special applications
- Training of installation staff
- Brochures and information material
- Technical drawings

Quality

Consistently high quality standards are an important feature of the Amipox pipe system. The manufacturing site is continually checked by a third party and has official approval under ISO 9001.

The plant has its own quality control department, to ensure that all products are manufactured according to the specified requirements.

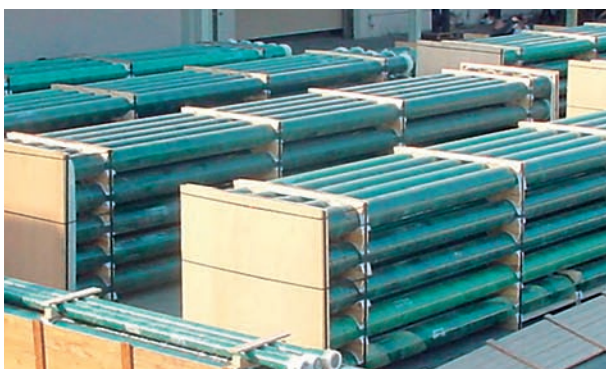

Research and Development

As well as manufacturing pipe products, the Amiantit Group also develops and supplies the technology for our Amipox product line. The Technology Centre ensures:

- The continuous development of products and processes
- Technical assistance, monitoring and exchange of experience between the different plants
- The provision of new plants as well as production equipment and spare parts

All our Research & Development Departments have dedicated and highly qualified staff. The departments, plants and products are certified under the most widely acknowledged international standards and approval systems.

Environment

We are fully aware of our responsibility for the environment, both locally and globally. We are therefore committed to active environmental protection measures in all our plants. This ensures the health and safety of our workers, and the general public. We produce and develop products which, when used according to their specifications, are both safe and reliable.

Logistics

Amipox Pipe Systems are supplied to countries throughout the world. Working closely with our customers, our experienced specialists in the Logistics Departments develop the most efficient way for transportation by rail, road, sea or air. Cost savings can be obtained by nesting the pipes, which is possible due to low weight and easy handling.

Utmost care has been taken to ensure that all contents of this brochure are accurate. However, **Amiantit** and its subsidiaries do not accept responsibility for any problems, which may arise as a result of errors in this publication. Therefore customers should make inquiries into the potential product supplier and convince themselves of the suitability of any products supplied or manufactured by **Amiantit** and/or its subsidiaries before using them.



Amitech Industrial

P.O. Box 589
Dammam 31421
Saudi Arabia
Phone: +966 3 847 15 00
Fax: +966 3 847 19 55

Europe

Amiantit Service GmbH

Am Seestern 18
40547 Düsseldorf
Germany
Tel.: +49 211 550 270 41
Fax: +49 211 550 270 99
office.dusseldorf@amiantit.de
www.amiantit.com

Distributed by: ■